

## Table of contents FABA 100

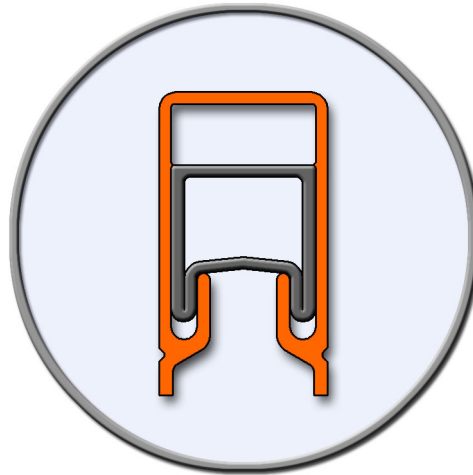
<b>General Information .....</b>	<b>1</b>
<b>Introduction</b>	<b>2</b>
Basic description	2
Typical applications	2
<b>Conductor Rail System FABA 100 for mobile equipment</b>	<b>3</b>
Technical data	3
<b>General remarks on planning</b>	<b>4</b>
A. Track Layout	4
B. Environment	4
C. Manual Operation	4
D. Electrical Transmission of Power	5
E. Data Transfer	6
F. Component information	6
G. General Installation Instructions	6
<b>Basic Diagram</b>	<b>7</b>
<b>Standard Components .....</b>	<b>1</b>
<b>Conductor-Rail</b>	<b>2</b>
<b>Conductor Rail with Hard PVC Insulation</b>	<b>2</b>
<b>Conductor Rail with Halogenfree Insulation</b>	<b>2</b>
<b>Technical Information</b>	<b>3</b>
<b>Planning Instructions</b>	<b>3</b>
<b>Installation Instructions</b>	<b>3</b>
<b>Rail-Connectors (plug-in type)</b>	<b>4</b>
Technical Information	4
Planning Instructions	4
Installation Instructions	4
<b>Rail-Connectors (screw-type)</b>	<b>5</b>
Technical Information	5
Planning Instructions	5
Installation Instructions	5
<b>Hanger-Clamp screw-type assembly</b>	<b>6</b>
Technical Information	7
Planning Instructions	7
Installation Instructions	7
<b>Power-Feeds</b>	<b>8</b>
Technical Information	9
Planning Instructions	9
Installation Instructions	9
<b>Expansion</b>	<b>10</b>
General	10
<b>Fixed Point</b>	<b>11</b>
Technical Information	11
Planning Instructions	11
Installation Instructions	11

<b>Expansion connector</b>	<b>12</b>
Technical Information	12
Planning Information	13
Assembly Instructions	13
<b>Expansion-Rail</b>	<b>14</b>
Technical Information :	14
<b>Expansion-Rail - Continuation -</b>	<b>15</b>
Planning Instructions	15
Installation Instructions	15
<b>Electrical-Separation</b>	<b>16</b>
Technical Information	17
Planning Instructions	17
Installation Instructions	17
<b>Transfer-Caps</b>	<b>18</b>
Technical Information	19
Planning Instructions	19
<b>Current Collector EAS-L   Spring Pressure approx. 4 N</b>	<b>20</b>
Standard Type	20
For Data Transfer	20
Technical Information	21
Planning Instructions	21
Installation Instructions	21
<b>Current Collector EAS-K   Spring Pressure approx. 2,5 N</b>	<b>22</b>
Technical Information	22
Planning Instructions	22
Installation Instructions	22
<b>Cleaning-Collector EAS-R   Spring Pressure approx. 4 N</b>	<b>23</b>
Technical Information	23
Planning Instructions	23
Installation Instructions	23
<b>Base-Plate   for current-collector EAS-L / EAS-K</b>	<b>24</b>
Technical Information	24
Planning Instructions	24
Installation Instructions	24
<b>Current Collector PAS-K   Spring Pressure approx. 4 N</b>	<b>25</b>
<b>Current Collector PAS-L   Spring Pressure approx. 6 N</b>	<b>25</b>
Technical Information	28
Planning Instructions	28
Installation Instructions	28
<b>Current collector PA DS-20   Spring Pressure approx. 7 N</b>	<b>29</b>
Technical information	30
Planning instructions	30
Installation instructions	30
<b>Tandem Collector DE AS-20   Spring Pressure approx. 2 x 4 N</b>	<b>31</b>
<b>Technical Information</b>	<b>32</b>
<b>Planning Instructions</b>	<b>32</b>
<b>Installation Instructions</b>	<b>32</b>

<b>FABA 30 Conductor Rail</b> .....	<b>1</b>
<b>Conductor Rail</b>	<b>4</b>
Technical Information	4
Planning Information	4
Assembly Instructions	4
<b>Rail Connector</b>	<b>5</b>
Technical Information	5
Planning Information	5
Assembly Instructions	5
<b>Hanger Clamp</b>	<b>6</b>
<b>Power feeds</b>	<b>7</b>
Technical information	7
Planning instructions	7
Installation instructions	7
<b>Expansion – General information</b>	<b>8</b>
<b>Expansion rail for building expansion</b>	<b>9</b>
Planning instructions	10
Installation instructions	10
<b>Electrical separation</b>	<b>11</b>
Technical information	12
Planning instructions	12
Installation instructions	12
<b>Mechanical separation</b>	<b>13</b>
Technical information	14
Planning instructions	14
Installation instructions	14
Technical Information	16
Planning instructions	16
Installation instructions	16
<b>Mechanical separation multiple-pole, 45°</b>	<b>17</b>
Technical information	17
Planning instructions	17
Installation instructions	17
<b>Mechanical separation Pick up guide</b>	<b>18</b>
Technical information	18
Planning instructions	18
Installation instructions	18
<b>Current collectors</b>	<b>19</b>
<b>Data Transfer</b> .....	<b>1</b>
<b>Introduction</b>	<b>2</b>
<b>General 3</b>	
<b>Location of the Conductor rail system</b>	<b>3</b>
<b>Selection of Components</b>	<b>4</b>

<b>Hanger Clamps .....</b>	<b>1</b>
General 2	
Technical Information	2
Planning Instructions	2
Installation Instructions	2
Hanger-Clamp           screw-type assembly	3
Technical Information	3
Hanger - Clamp Clip-type - Assembly height 27 mm	4
Technical Information	4
Hanger - Clamp Clip-type - Assembly height 32 mm	5
Technical Information	5
Hanger - Clamp Clip-type - Assembly height 40 mm	6
Technical Information	6
Hanger – clamp   Stud – mounting with spring clip	7
Fastening-Consoles	8
<b>Checking Devices .....</b>	<b>1</b>
Introduction	2
Collector shoe wearing tester	3
Working mode	3
Technical information	4
Planning instructions	4
Installation instructions	4
Maintenance	4
<b>Dust Removal .....</b>	<b>1</b>
Introduction	2
Vaccuum and accessories	3
Vacuum and accessories           - Continuation –	4
Procedure	4
Technical Information	4
Planning Instructions	5
Installation Instructions	5
<b>Transfer Sections .....</b>	<b>1</b>
Mechanical Separations           For Individual Selection	3
Conductor-Rail-Transfer   Complete	4
Technical Information	5
Planning Instructions	5
Installation Instructions	5
Conductor-Rail-Transfer	6
Technical Information	7
Planning Instructions	7
Installation Instructions	7

<b>Conductor Rail Transfer</b>	<b>8</b>
<b>Technical Information</b>	<b>9</b>
<b>Planning Instructions</b>	<b>9</b>
<b>Installation Instructions</b>	<b>9</b>
<b>Conductor-Rail-Separations pick-up guide for current collectors</b>	<b>10</b>
<b>Technical Information</b>	<b>10</b>
<b>Planning Instructions</b>	<b>10</b>
<b>Installation Instructions</b>	<b>11</b>
<b>Pre-assembled System .....</b>	<b>1</b>
<b>Introduction</b>	<b>2</b>
<b>Conductor rail</b>	<b>3</b>
Technical information	4
<b>Diagram</b>	<b>5</b>
Planning instructions	6
Installation instructions	6
<b>Maintenance Manual FABA 100 .....</b>	<b>1</b>
<b>Cleaning instructions for FABA 100 conductor rails</b>	<b>3</b>
<b>Discontinued Components .....</b>	<b>1</b>



# FABA-Conductor-Rail-Systems System FABA 100

for mobile equipment

### Conductor Rail System FABA 100 for mobile equipment

#### Introduction

During the last years this system has been employed under the most diverse conditions. In the performance of the various requirements on the system a multitude of components resulted which today we offer as standard. All required technical data as well as necessary notes on the planning and installation these are shown in the following lists.

Since we do not produce factory-completed equipment (such as machines) but individual components which are assembled on site for the FABA 100 Insulated Conductor Rail System much care has to be taken when the installation is very extensive or special requirements have to be observed. Please remember that for the selection and determination or ordering system components not every question on the list can be answered and hence, some experience is required; hence we suggest you plan or perform the installation with our assistance or have it done by us.

We look for and find for you the optimum, especially a dependable solution valid to existing regulations.

**The generally accepted technical rules are to be observed during the planning, the erection and during the operation.**

The components of the FABA 100 system correspond with the DIN standards and VDE regulations and are to be employed and used accordingly.

#### Basic description

1. Reliable and proven electric power-, control command- and data transfer.
2. Permissible continuous current (at 100% DC) for FABA 40 = 40 Ampere for FABA 100 = 100 Ampere
3. Permissible operating voltage up to 1000 V.
4. Permissible travelling speed up to 400 m/min.
5. For continuous ambient temperatures from – 30°C to + 55°C for the standard insulation,  
– 30°C to + 80°C for the heat-resistant insulation.
6. Installation in dry interior spaces; with additional measures in damp, wet interior spaces and outdoors.
7. IP 2x = protection against accidental contact with all live (potential carrying) parts.
8. For potential above 50 V alternating- or 120 V direct current the system is to be installed outside the manual area.
9. The number of poles are unlimited .
10. Possible arrangement of the conductor surface down or sideways.
11. The rail centre distance is 15 mm.
12. The single current collectors for permissible continuous currents up to 50 A are fastened to the mobile equipment.
13. As is usual for example for the electric monorail (AMS), computer-aided data may be transferred simultaneously and reliably to several mobile carriers via the conductor rails.
14. The FABA 100 system is, by experience, extremely low in maintenance.

#### Typical applications

Electric monorails • Light girder cranes, longitudinal- and traversing travel • shelve systems • machine tools, automated assembly lines • devices, robots moving - of course also three-dimensionally - through extended and / or work areas very rapidly • Slip rings with arbitrary number of poles, from a diameter of 400 mm.

*For all operating equipment data transfer may be carried out flawlessly during standstill as well as for travelling speeds up to 20 m/sec and that during unidirectional traffic as well as during reversing traffic. Please refer to list IS 100 D for this.*

*The system may of course also be used under different conditions, if however, special measures or changes are required. Please talk to us if you require our assistance. Expert field agents will be glad to assist you. You will meet a knowledgeable partner with many years of experience.*

## FABA – a product of FAHRLEITUNGSBAU GmbH

### Conductor Rail System FABA 100 for mobile equipment

#### Technical data

		FABA 40	FABA 100
Metal rail	a) Cross - section	a) 24 mm <sup>2</sup>	a) 24 mm <sup>2</sup>
	b) Material	b) Steel, galvanised	b) copper
Permissible cont. current : (100 % Duty cycle)	a) Standard-Isul. Up to 35°C amb. Temp.	a) <b>40 Ampere</b>	a) <b>100 Ampere</b>
	b) Heat resistant-Isul. Up to 55°C amb. temp.	b) 40 Ampere	b) 100 Ampere
Resistance of metal rails at amb. Temps. up to 35°C :	a) For altern. current (50 Hz), impedance 15 mm centre distance	a) Z = 0,00532 Ohm/m	a) Z = 0,00078 Ohm/m
	b) For direct current	b) R = 0,00493 Ohm/m	b) R = 0,00077 Ohm/m
Coefficient of linear expansion for the conductor rail		$\alpha = 12 \cdot 10^{-6} [K^{-1}]$	$\alpha = 17 \cdot 10^{-6} [K^{-1}]$
Conductor rail :	a) Number of poles b) length c) Hanger distance d) Centre distance min e) Bending radius = possible „on site“	a) from 1 till $\infty$ , i.e. arbitrarily selected b) 3 m and 5 m c) In straight sections max. 0,8 m, in bends max. 0,4 m d) 15 mm e) min 500 mm, in all directions	
Insulating sleeve	a) Colour for standard insulation b) Colour for heat resistant insulation c) Same lengths as metal rail d) materiel e) Combustibility	a) Current conductor rails orange, ground conductor rails yellow with continuous green stripe b) Current conductor rails black, ground conductor rails green with continuous yellow stripe c) Easy shortening "on the site" possible d) Standard design: hard PVC Heat resistant design: heat resistant hard PVC e) Flame-resistant, self-extinguishing	
Current collector:	a) Number of poles b) System c) For each conductor rail, (current- / data- / ground-) d) Permissible continuous current (at 100 %) at 35°C amb. Temp. e) Fastening to the operating equipment f) Operating area g) Collector shoe h) Collector shoe, material	a) from 1 to multi-poles arbitrarily selected b) Individual design (each "operates" on its own) c) Basically only 1 current collector required d) One-arm design = 16 c.e.. 20 Ampere Parallel-arm-design = 20, 30, 40, 50 Ampere e) All neighbouring collectors attachable in series f) One-arm design, stroke $\pm 15$ , swivel $\pm 20$ mm One arm small, stroke $\pm 8$ , swivel $\pm 8$ mm Parallel-arm, stroke $\pm 15$ , swivel $\pm 20$ mm Parallel-long-arm, stroke $\pm 30$ , swivel $\pm 50$ mm g) The length of the collector shoe bridges switch-junctions, expansion points and similar separations h) Copper graphite silver containing carbon for data transfer	
For the complete system	a) Permissible operating voltage b) Travelling speed c) Application d) Arrangement of the rail conductor surface e) Protection against accidental contact With live parts f) Permissible continuous ambient temperature g) Expansion points h) Electrical separation points k) Mechanical separation l) Chemical resistively m) Combustibility (insulation casing, refer there)	a) Up to 1000 V b) Up to 400 m/min (on occasion even more) c) Indoors/outdoors with additional cover d) Selectively down or sideways e) IP 2x f) - 30 °C to + 55 °C for standard insulation - 30 °C to + 80 °C for heat-resistant insulation g) Yes; at arbitrary locations by caps h) Yes; at arbitrary locations by caps k) Yes, with caps on switches; Pick up guides for extended separations for parallel-arm conductors l) Largely resistant against gasoline, oils dilute bases and dilute acids m) UL 94 V-O	

The data refer to our usual listed component parts (unless specified differently).  
For special requests - please contact us !



### Conductor Rail System FABA 100 for mobile equipment

#### General remarks on planning

- \* Plan and construct the installation in such a way as to avoid dangerous situations.
- \* Appropriate counter measures have to be instituted if wrong-doings of personnel is to be expected.

#### A. Track Layout

1. For the desired compact installation of the system, special attention is to be paid that the conductor rails are installed in a way as not to impede the free movement of the current collectors moving through the complete installation - including bends etc. - ; please refer to : "Operating Range of the Current Collector".
2. Basically the system is suitable for a back and forth operation.  
Special precautions do not have to be taken.
3. Very careful planning and installation is a prerequisite for travelling speeds above 400 m/min .
4. Radii of more than 0.5 m for conductor rails are possible in all directions, hence, horizontal-, vertical bends and inclines can be realised. Rails with radii of less than 0.5 m can only be bent at the factory, please consult us.
5. Mechanical interruptions of the conductor rails with transfer caps e.g. for pivot- and sliding switches, shunting stages, hoist stations have to be installed correctly, so that the permissible displacement of the opposing caps - also while loading just one end of the switch - is not exceeded.

#### B. Environment

1. In dry interior spaces the system can be employed without restrictions.
2.
  - a) In damp areas Conductor Rail centers are to be 30 mm and installed hanger clamp height 40 mm to prevent current creepage.
  - b) In dry interior spaces dripping water has to be deflected by covers.
  - c) In areas where water jets are in operation, the rails are to be installed as stated under a); they may only be sprayed when turned off.
3. For outdoor installations the rails are to be installed as described in section 2. a), with an additional cover.
4. Do not employ in areas of explosion hazard.
5. Conductor rails which are planned for areas where external mechanical demands (e.g. use of ladders) are to be expected have to be provided with covers (at least in part).
6. On danger of external heavy showers of sparks (welding- or grinding sparks) covers are to be installed in this area.
7. Please consult us if the conductor rail system is to be exposed to extreme chemical influences.
8. The system cannot be heated.

#### C. Manual Operation

1. Without limitations for operating voltages up to 60 V alternating- or 120 V direct current.
2. Beyond that:
  - a) Without limitations in electrical/locked electrical operating locations.
  - b) In general operating locations the personnel have to be protected by screening at a suitable distance.  
Safety distance/manual operation is 2.5 m in height and 1.25 m to the side measured from the floor.
  - c) Additional measures have to be taken if there is danger of touching the live conductor surface with thin, conducting objects (e.g. ends of wires).
3. Please contact us for the transmission of voltages above 1000 V.
4. Final temperatures up to 75°C may develop for the standard insulation or of up to 100°C for the heat-resistant insulation.

### D. Electrical Transmission of Power

Since the system is employed for varying purposes, we restrict ourselves to general, however important facts which should be considered.

1. Current capacity of the conductor rails - refer to Table 1 :  
In determining the total current - i.e. all users - the following is to be considered :
  - a) How often or at which points is the system to be supplied ?
  - b) How are the users (or is the user) utilised, or how large is the duty cycle (DC) ?
  - c) How high is the expected maximum ambient temperature ?

Table 1 = Conductor rails		permissible continuous current [A] for 100 % Duty cycle									
		for continuous ambient temperature up to [°C]									
	Insulation	35	40	45	50	55	60	65	70	75	80
<b>FABA 40</b>	Standard	40	36	32	28	24	--	--	--	--	--
steel	Heat-resistant	40	40	40	40	40	35	30	25	20	15
<b>FABA 100</b>	Standard	100	90	80	70	60	--	--	--	--	--
copper	Heat-resistant	100	100	100	100	100	90	80	70	60	50

2. Potential drop :
  - a) The potential drop for conductor rails is in general not to be more than 3 %.
  - b) It is to be considered how often or at which points the system is to be supplied.
  - c) The resistance of the conductor rails increases with higher ambient temperatures - refer to table 2.  
We have listed the most unfavourable values; they were determined under continuous currents of 40 A for FABA 40 and 100 A for FABA 100.

Table 2 = Conductor rails		Resistance [Ohm/km]					
		for continuous ambient temp. up to [°C]					
	for	35	40	50	60	70	80
FABA 40	Altern. current (impedance); 50 Hz; 15 mm center separation	5.32	5.48	5.85	6.25	6.73	7.28
	Direct current	4.93	5.08	5.38	5.80	6.24	6.75
FABA 100	Altern. current (impedance); 50 Hz; 15 mm center separation	0.78	0.83	0.95	1.05	1.18	1.34
	Direct current	0.77	0.82	0.94	1.04	1.16	1.32

3. Conductor rail for the ground conductor :
  - a) Whether and when the ground conductor rail is employed is to be determined for the individual installation - e.g. users with small protective voltage? User protectively insulated?
  - b) Consider the ambient temperature possibly developing; standard- or heat-resistant insulation ?
  - c) Do not use ground conductor rails for control purposes.
  - d) Arrangement may be carried out individually. We suggest to locate it in the front if there is danger of contact.
4. Current capacity of the current collectors - refer to table 3 :
  - a) The ambient temperature has to be considered.
  - b) **In principle only one current collector** is required per conductor rail for the transmission of power.

Table 3 = Current collector		Permissible continuous current [A]					
		for 100 % Duty cycle					
		for continuous ambient temp. up to [°C]					
		35	40	50	60	70	80
One-arm current collector		20	20	16	12	8	4
	small; with cable 0,75 mm <sup>2</sup>	10	10	8	6	4	2
	with cable 1,5 mm <sup>2</sup>	16	16	12	9	6	3
Parallel-arm collector with cable.....	1,5 mm <sup>2</sup>	20	20	16	12	8	4
	2,5 mm <sup>2</sup>	30	30	25	20	15	10
	4,0 mm <sup>2</sup>	40	40	33	26	20	14
	6,0 mm <sup>2</sup>	50	50	42	34	26	18
Parallel-arm collector, long arm with cable	1,5 mm <sup>2</sup>	20	20	16	12	8	4
	2,5 mm <sup>2</sup>	30	30	25	20	15	10
	4,0 mm <sup>2</sup>	40	40	33	26	20	14
	6,0 mm <sup>2</sup>	50	50	42	34	26	18

5. Current collector for the ground conductor :  
As for the transmission of power, only one current collector is required for the ground conductor rail.

### Conductor Rail **System FABA 100** for mobile equipment

#### General remarks on planning - Continuation

#### E. Data Transfer

1. Please consider the special list IS 100 D "Data Transfer" with its detailed information.
2. For simple tasks, e.g. to trigger control commands, electric or isolation separations are arranged in additional conductor rails; use current collectors with copper-carbon.
3. For the computer-aided data transfer additional conductor rails (and only those of copper) and current collectors with silver-carbon - for this case perhaps two current collectors per rail - are to be planned for.
4. We suggest to make use of our assistance when needed.

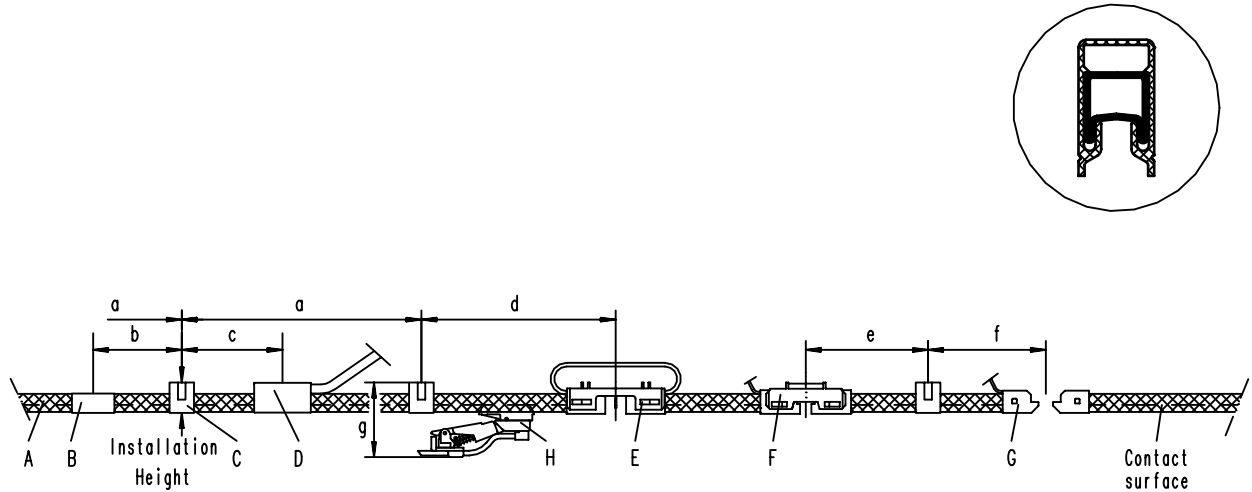
#### F. Component information

1. **Conductor rails :**
  - a) Arrangement of the collector surface down or sideways.
  - b) Arbitrary number of poles possible.
  - c) Minimum and usual rail center separation of 15 mm.
  - d) Hanger- or support separation for straight sections of max. 0.8 m, in radii/bends of max. 0.4 m
2. **Hanger clamps :**
  - a) One-pole for rail center separations of 15 mm or larger.
  - b) Multi-pole for rail center separations of 15 mm.  
**Important!** Pay attention to the assembly height, choice 27, 32, 40 mm. The construction height remains the same even for further components in the complete installation and is of importance if the system is to be fastened to continuous webs - such as for electric monorails for example - .
3. **Feeds :**
  - a) Power feeds of up to 100 A are possible at each conductor rail joint, a single-core feed cable is required.
  - b) Furthermore it is possible to feed (also for control currents, data transfer and similar) at separation points such as switch transfer locations etc. and also at the beginning or the end of a system:
4. **Expansions :**
  - a) Only centered fix points are to be arranged for linear systems of up to 60 m where the end caps can expand. For changes in length of the conductor rail (caused by fluctuations of the ambient temperature and / or current heating) the conductor rails slide in their hanger clamps.
  - b) Expansion points are to be provided for installations longer than 25 m and in the straight stretches and between bends where both ends are fixed firm e.g. through switches lifts etc.
5. **Separation points :**
  - a) Electric separations of the conductor rails can be provided at practically every point of the system, e.g. at repair stretches; they may serve to trigger control pulses. The separation points or separation caps may be provided with connecting cables depending on the requirement.
  - b) Mechanical separations are required for switches and lift sections. They are installed by affixing transfer caps which are available in one-pole and multi-pole design. The power feed is possible on these caps.:
  - c) The separation points are installed so that they may be bridged by one collector shoe, i.e. usually only one current collector is required per conductor rail, however, the instructions on the components are to be observed.
  - d) Pick up guides are available for large conductor rail separations. Because these are not in daily use please observe the special list IS 100 U.

#### G. General Installation Instructions

1. No special tools are required for simple installations in straight sections.
2. For branched stretches - typical for the electric monorail -, or for extended installations it is certainly helpful to use the tools shown in the list of accessories or tools, i.e. they are to a large extent of vital importance.
3. First mark all conductor rail hanger locations and install the hanger clamps in a well aligned manner.
4. Start the further installation in the area of switches, hoist stations, lift sections and bends; these have to be definitely carefully pre-aligned
5. **Inspection at the end of the installation :**
  - Are conductor rails correctly engaged in the hanger clamps ?
  - Do both sides of all housings (joint / feed) and all caps embrace the insulating sheath of the conductor rails?
  - Are all screws and bolts securely tightened, e.g. rail connectors to be screwed?
  - Have all burrs been removed on the contact surface ?
  - Are all cables connected?
  - Are the transfers at mechanical separation points - such as switches - in operating order?
  - Is the expansion gap correctly adjusted? Fixed points installed ?

### Basic Diagram



- Measurement a **Hanger clamp distance** : max. 800 mm in straight sections and 400 mm in bends.  
Separation of support clamps; adhered to on at least one side as follows :
- Measurement b **For the rail connector** of the conductor rail : min. least 100 mm; max. 200 mm.
- Measurement c **For the feed** : min. 100 mm; max. 200 mm.
- Measurement d **For the expansion** : min. 100 mm; max. 200 mm.
- Measurement e **For separations with separation caps** : min. 100 mm; max. 200 mm supported both sides.
- Measurement f **For the separation with transfer caps** : min. 50 mm; max. 100 mm.  
Please refer to the special list IS 100 U for this.
- Measurement g **Height of system** = upper edge of hanger clamp to lower edge of current collector fastening :  
Note : Assembly height is the height of the hanger clamp.

#### with standard collector

for assembly height 27 = 73 mm;  
for assembly height 32 = 78 mm;  
for assembly height 40 = 86 mm

#### with standard small collector

for assembly height 27 = 71 mm;  
for assembly height 32 = 76 mm;  
for assembly height 40 = 84 mm

#### with double arm collector

for assembly height 27 = 98 mm;  
for assembly height 32 = 103 mm;  
for assembly height 40 = 111 mm

#### with long double arm collector

for assembly height 27 = 108 mm;  
for assembly height 32 = 113 mm;  
for assembly height 40 = 121 mm

#### with double shoe collector

for assembly height 27 = 98 mm;  
for assembly height 32 = 103 mm;  
for assembly height 40 = 111 mm

### FABA – a product of FAHRLEITUNGSBAU GmbH

#### A Conductor Rail

FABA 40 for 40 A, FABA 100 for 100 A; both types are of equal dimensions; 3 m or 5 m long; Collector arrangement selectively facing down or sideways; unlimited number of poles possible; radii from 0.5 m; under 0.5 m only bent at the factory; simple installation by clipping into the hanger clamp.

#### B Rail Splice Connector

Screw-type or plug-in type for quick installation.

#### C HANGER CLAMP

Determine the construction height according to your local conditions, selectively 27 or 32 or 40 mm.

Use only :        32 mm or 40 mm for crane installations, for mounting to consoles for example.  
                      27 mm only for small mounting Systems (EHB);

Construction :    Use a 1-pole hanger clamp 32 mm height for rail centres for more than 15 mm.  
                      Use a multi pole hanger for 15 mm centres.

Hanger clamps to be screwed are shown in this list. Further designs are found in the supplementary list IS 100 K, those that directly clip onto the electric monorail tracks for example.

#### D POWER FEED

Up to 50 A etc. 100 A at the conductor rail joint; use a single-core connection cable.

#### E EXPANSION

Shown is the "expansion bridge" design: an air gap remains between the ends of the conductor rails, i.e. a change in length of the conductor rails of up to 25 mm (caused by heat / cold) can be compensated here. A fixed point is to be installed between two expansion points.

#### F SEPARATION WITH SEPARATION CAPS

For electrical interruption, e.g. at repair sections or to trigger control pulses; with the possibility of single-core feed at one or both sides;

Remark:        An air gap remains between the plugged-in separating caps, i.e. changes in lengths of the conductor rails up to 10 mm can be compensated here.

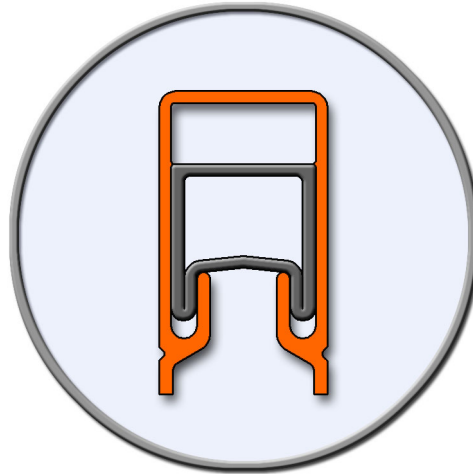
#### G Separation with transfer caps

For example for switches, hoist stations with feed-in possibility.  
If required consider also the special list IS 100 U with its installations with pick up guides.

#### H CURRENT COLLECTOR

Single-design: each "operates" independently; usually only one current collector is required per conductor rail; suitable for unidirectional- and reversing operation; unrestricted travelling speed of up to 400 m/min, for robot-machines and similar, even more. the highly flexible connecting cables are one-core and are fastened to the exchangeable head or wear part.

- One-arm current collector 16 or 20 A; for a conductor rail centre separation of 15 mm; are plugged onto one common base plate; the base plate is bolted to the equipment.
- Parallel-arm current collector for 25 or 50 A; for a conductor rail centre separation of 20 mm or more;



# FABA-Conductor-Rail-Systems

## System FABA 100

## Standard-Components

for mobile equipment

### Conductor-Rail

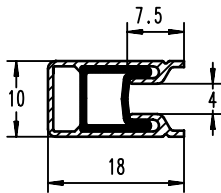


Fig. 1

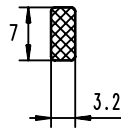


Fig. 2

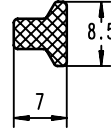


Fig. 3

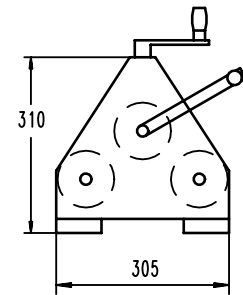


Fig. 4

### Conductor Rail with Hard PVC Insulation

Order-No.	Fig.	Identification	Length	Material	Insulation hard-PVC		Weight
200 009 299	1	Conductor rail <b>FABA 40</b>	3 m	Metal-rail	Standard	orange	0,720
200 009 499			5 m		Standard	orange	1,200
200 010 299			3 m	steel galvanised	Standard	PE Ground yellow with green stripe	0,720
200 010 499			5 m		Standard	PE Ground yellow with green stripe	1,200
201 009 299	1	Conductor-rail <b>FABA 100</b>	3 m	Metal-rail	Standard	orange	0,805
201 009 499			5 m		Standard	orange	1,340
201 010 299			3 m	copper	Standard	Ground yellow with green stripe	0,805
201 010 499			5 m		Standard	Ground yellow with green stripe	1,340

### Conductor Rail with Halogenfree Insulation

Order-No.	Fig.	Identification	Length	Material	Insulated halogen-free		Weight
206 009 299	1	Conductor rail <b>FABA 40</b>	3 m	Metal-rail	Heat-resistant	orange	0,720
206 009 499			5 m		Heat-resistant	orange	1,200
206 010 299			3 m	steel galvanised	Heat-resistant	PE Ground yellow with green stripe	0,720
206 010 499			5 m		Heat-resistant	PE Ground yellow with green stripe	1,200
207 009 299	1	Conductor-rail <b>FABA 100</b>	3 m	Metal-rail	Heat-resistant	orange	0,805
207 009 499			5 m		Heat-resistant	orange	1,340
207 010 299			3 m	copper	Heat-resistant	Ground yellow with green stripe	0,805
207 010 499			5 m		Heat-resistant	Ground yellow with green stripe	1,340
241 000 005	2	Bending strip	1 m	Hard PVC black	Ring material 100 m	Ring material 100 m remains in rail	3,200
241 000 015	2	Bending strip	1 m	Halogen free Orange	Ring material 100 m	Please specify the length in your order	
241 000 006	3	Bending profile	5 m	PVC red	Straight profile	multiple use	0,250
241 045 001	4	Bending machine				for manual operation	11,20
518 503 000	without	Fine file					0,095
518 505 000	without	Hacksaw					0,135
518 505 010	without	Blades	(spares; 12 Pieces)				0,038

### Conductor-Rail - Continuation -

#### Technical Information

- Permissible continuous current (for 100 % Duty Cycle): FABA 40 = 40 A, FABA 100 = 100 A; for standard insulation up to an ambient temperature of 35 °C, for heat-resistant insulation up to an ambient temperature of 55 °C. For higher ambient temperatures reduce according to table 1, list IS 100 A.
- Permissible continuous ambient temperatures: from – 30°C to + 55°C for standard insulation, from – 30°C to + 80°C for heat-resistant insulation.
- **Refer to table 2 of list IS 100 A for the resistance of the conductor rails also for different ambient temperatures.**
- Metal rail and insulating sleeve are of equal length.

#### Planning Instructions

- Conductor rails may be shortened "on site".
- Radii are possible in all directions : bending radii larger than 0.5 m "at the site"; bending radii from 0.2 m to 0.5 m can only be bent at the factory, please inform us if required.
- In general, the use of rail lengths of 5000 mm is standard. However where cramped physical conditions are present, the length of 3000 mm is to be recommended for better handling.

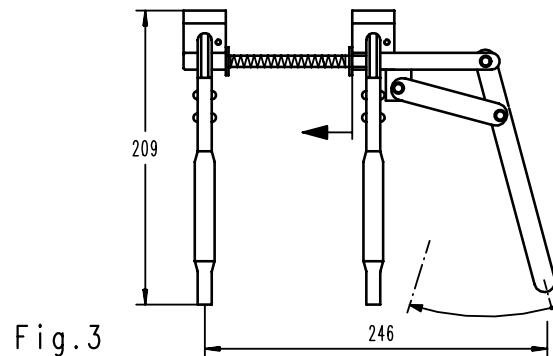
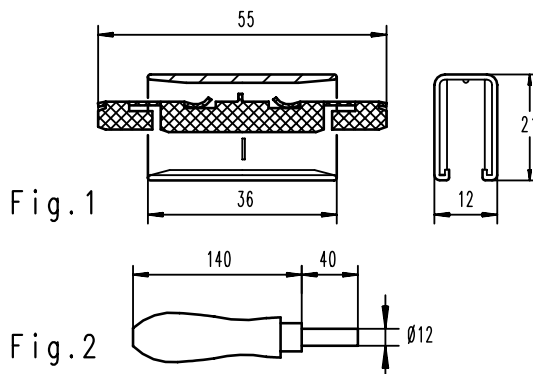
#### Installation Instructions

- a) Hanger clamp distance :

In straight runs,	max. 800 mm,
In bends,	max. 400 mm.
- b) Shortening : With fine-toothed hacksaw, start sawing at the conductor surface. De-burr the cuts - especially the metal conductor surface - with a fine file
- c) Bends : Carried out with the bending machine with bending strips; generally "done on site", if requested at the factory. The smallest bending radius to all sides is 500 mm.
  - Determine the approximate length of the curve and mark it with a felt pen on the insulating sleeve. Mark at least 150 mm from the end of the rail (both ends of the rail cannot be bent and remain straight).
  - When bending over the conducting surface or the back of the rail insert the grey bending strip between the back of the metal rail and the insulating sleeve. When using the "screw-type" rail connector and / or the separating- or transfer caps insert the strip 40 mm shorter. After bending retract the strip by 20 mm.
  - When bending over the wide side of the rail the red bending profile has to be inserted into the slit of the conductor surface and the grey bending strip has to be inserted into the back of the rail.
  - Insert the rail into the bending machine until the first mark on the bend is centred over one of the lower rolls. Tighten the upper roll depending on the required radius. Slide the rail through the machine up to the second marking. It is possible to make corrections by again passing the rail through the machine. Record the scale setting for equal bends.
  - If two bent rails have to be joined, shorten the rails to be joined by the straight end (approx. 150 mm). Use only "screw-type" rail connectors.



### Rail-Connectors (plug-in type)



Order No.	Fig..	Identification		Weight
241 002 010	1	Rail connector, plug-in	one-pole; complete; packed unit, in bag	0,008
241 026 006	1	Housing	Plastic-black	<i>only as spare</i> 0,003
241 026 015	1	Plug-in connector	Bronze spring-steel	<i>only as spare</i> 0,005
241 046 020	2	Installation handle	Metal end with bore of $\varnothing 8,5$	0,135
241 046 010	3	Connecting vice		1,296

#### Technical Information

- Permissible continuous current 100 A (for 100 % Duty Cycle).
- Permissible ambient temperatures – 30 °C to + 80 °C .

#### Planning Instructions

- Distance to the next hanger clamp: min. 100 mm; max. 200 mm.
- Preferably for quick installation of extensive systems.
- Do not use in bends.
- The rail connector is not remountable / reusable.

#### Installation Instructions

Insert the plug connector into the installation handle.

Press the plug connector to the stop into the not yet mounted conductor rail.

Slide the housing onto the end of the conductor rail (over the plug connector) until the stop.

Clip the rail into the already installed hanger clamps.

Guide the rail to the one already installed.

Slide on the housing; take care that the sides of the housing embraces both insulating sheaths!

Fix the connecting vice to both sides of the joint :

tighten both tongues; hold the tongue which grips the already installed rail with the left hand; using the right hand push the handle so that the conductor rails are drawn completely together (to be reversed for "left-handed" persons).

**Inspection :** Are both insulating rims embraced by both sides of the housing?

**Disassembly :**

If the connection of the conductor rail has to be separated, it has to be cut out – approx. 60 to 70 mm. With a fine-toothed hacksaw from the side of the conductor surface - refer to "shortening" of conductor rail.

### Rail-Connectors (screw-type)

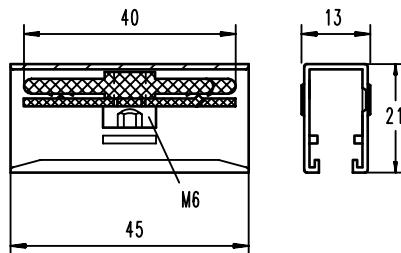


Fig. 1

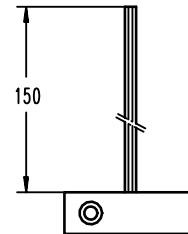


Fig. 2

Order-No.	Fig	Identification		Weight
241 002 000	1	Rail connector, screw-type	one-pole; complete; Packed unit, in bag	0,017
241 026 005	1	Housing	Plastic-black	<i>Only as spare</i> 0,003
251 002 000	1	Screw connector	Clip with spring-steel and screw M 6	<i>Only as spare</i> 0,014
518 501 010	2	Screwdriver 4 mm	for recessed hex-bolt	0,036

### Technical Information

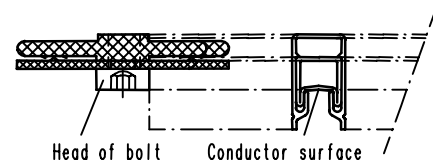
- Permissible continuous current 100 A (for 100 % Duty Cycle).
- Permissible ambient temperatures – 30 °C to + 80 °C.

### Planning Instructions

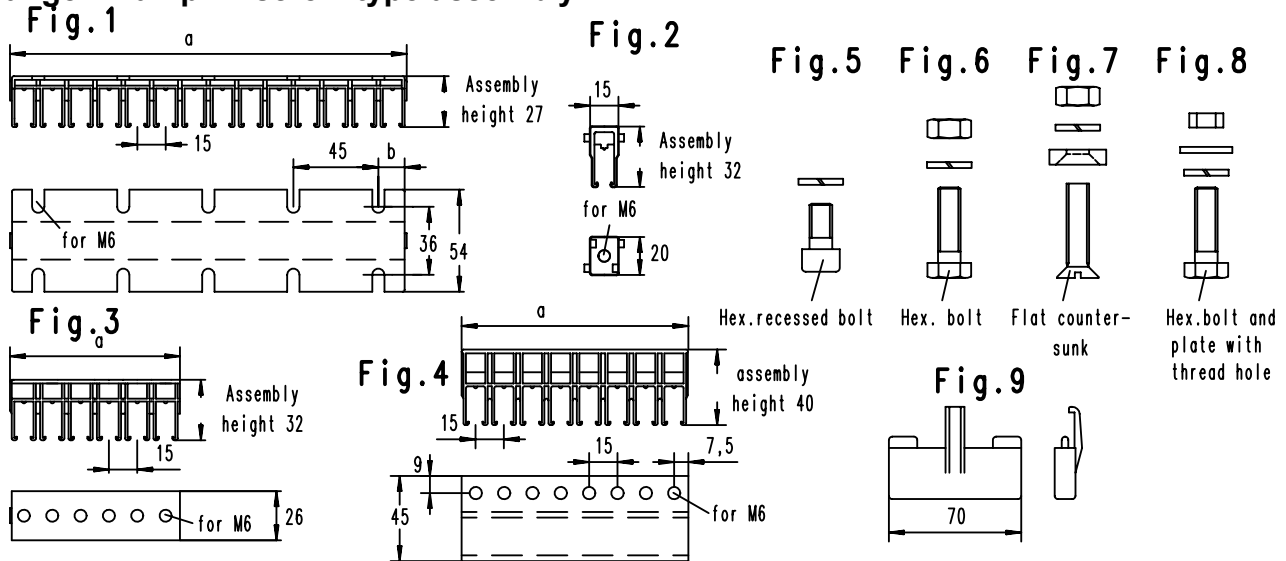
- Distance to the next hanger clamp: min. 100 mm; max. 200 mm.
- Preferably for smaller installations.
- Used also for joints of conductor rails in bends.
- The rail connector is remountable / reusable several times.
- A gap of 10 mm remains between the ends of the conductor rails.

### Installation Instructions

- Slightly loosen the screw of the screw connector with the screw driver.
- Insert the screw connector into the already installed conductor rail.
- Slide on the housing; pay attention that the housing embraces the insulating sleeve rims!
- Clip the next conductor rail into the already installed hanger clamp.
- Guide the conductor rail to the joint and slide together until the stop; take care that the housing completely embraces the insulating sleeve rims!
- Tighten the screw securely using a Allen key screwdriver.
- Inspection : Are both insulating sleeves embraced by both sides of the housing?



### Hanger-Clamp screw-type assembly



Order-No.	Fig.	Identification	Height	a	b	Assembly	weight					
241 006 128	1	Hanger-clamp	27 mm	4-poles	60	30	One piece	0,015				
241 006 127				5-poles	75	15		0,019				
241 006 137				6-poles	90	30		0,023				
241 006 126				7-poles	105	30		0,026				
241 006 130				8-poles	120	15		0,030				
241 006 131				9-poles	135	30		0,034				
241 006 132				10-poles	150	30		0,038				
241 006 133				11-poles	165	15		0,042				
241 006 134				12-poles	180	45		0,045				
241 006 135				13-poles	195	45		0,049				
241 006 136				14-poles	210	15		0,053				
241 003 000				2	Hanger-clamp 1-polig	32 mm		continues		One piece; Plastic-orange	0,004	
241 009 211				3	Hanger-clamp	32 mm		2-poles	30		One piece;	0,006
241 009 212								3-poles	45			0,009
241 009 213	4-poles	60					0,012					
241 009 214	5-poles	75					0,015					
241 009 215	6-poles	90					0,018					
241 009 216	7-poles	105					0,021					
241 009 217	8-poles	120					0,024					
241 009 218	9-poles	135					0,027					
241 009 219	10-poles	150					0,030					
241 009 220	11-poles	165					0,033					
241 009 210	12-poles	180					0,036					
241 009 223	4	Hanger-clamp	40 mm				4-poles	60		One piece;		0,020
241 009 224				5-poles	75		0,025					
241 009 225				6-poles	90		0,030					
241 009 226				7-poles	105		0,035					
241 009 227				8-poles	120		0,040					
241 013 000	5	Screw set	M6 x 12	For threaded hole	With spring washer;	Set; zinc-plated, in bag	0,005					
241 013 001	6	Screw set	M6 x 20	For through hole	With spring washer and nut;	Set; zinc-plated, in bag	0,008					
241013 003	7	Screw set	M6 x 25	For clamp Fig. 1	With washer orange, spring washer and nut	Set; zinc-plated, in bag	0,010					
241 013 022	8	Screw set	M6 x 12	For clamp Fig. 3	With washer, spring washer and plate with thread hole	Set; zinc-plated, in bag	0,008					
241 013 023		Screw set	M6 x 16				0,009					
241 013 024		Screw set	M6 x 20				0,010					
241 046 021	9	Dismantling wedge			For removing rail from hanger clamps	Plastic-orange	0,014					

### Hanger-Clamp screw-type - Continuation -

#### Technical Information

- Permissible ambient temperatures – 30°C to + 80°C.
- FABA hanger clamps guarantee good sliding characteristics for the conductor rail during the expansion process.
- Besides the hanger clamp shown, we manufacture other types as well, in particular clip-in types for (electric monorail tracks), corresponding to special list IS 100 K, examples of fastening and consoles are shown there.

#### Planning Instructions

- Recommendation for application :

Construction Height	27 mm for confined installation conditions only; 32 mm for crane installations for example, for mounting to consoles; 40 mm for crane installations for example, for mounting on consoles.
---------------------	--
- The 1-pole type is preferably used for conductor rail center separations larger than 15 mm; for example 30 mm centers for outside application.
- For multi-pole hanger clamps with an assembly height of 32 mm and above control and feed cables may be passed through openings above.
- The installation of the ground rails is possible at an arbitrary location.
- **Distances of hanger clamps: in straight sections max. 800 mm, in bends max. 400 mm, to the ends of the conductor rails min. 100 mm, max. 300 mm.**
- The hanger clamps are screwed to the consoles, tracks or similar with M 6 screws : the multi-pole types are to be fastened left and right, above poles at the center also.
- Standard-screw-fastening material according to fig. 5 ;fig. 6,fig. 7 and fig. 8; other screw connetions on request.

#### Installation Instructions

- Depending on the type of the installation the hanger clamps are fastened directly or by means of consoles to the track / conductor rail; they have to be perfectly aligned.
- The conductor rails are simply clipped into the hanger clamps until they snap in with a click !
- **The conductor rail can be removed from the hanger clamp at any time: spread the sides of the hanger clamp; for extensive systems we suggest the use of the dismantling wedge.**

### Power-Feeds

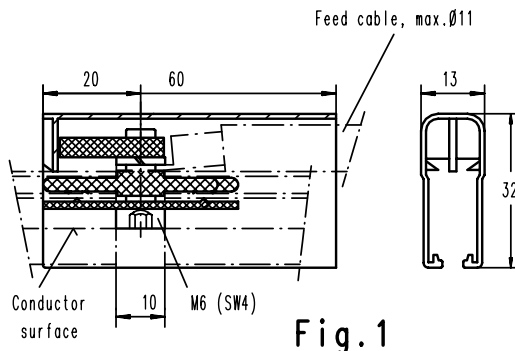


Fig. 1

For 32 mm height and above

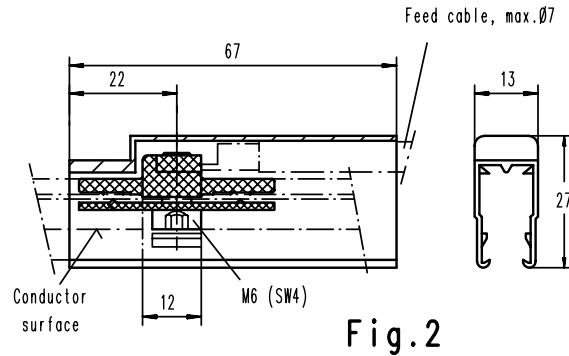


Fig. 2

For 27 mm height

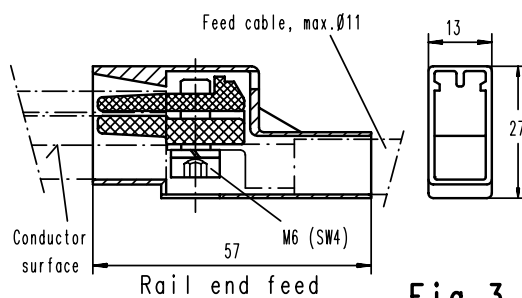


Fig. 3

Rail end feed

Fig. 4

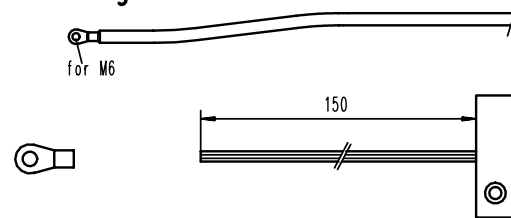


Fig. 5

Fig. 6

Order-No.	Fig.	Identification		Weight		
241 015 000	1	Splice-feed <b>100 A</b>	one-pole; complete; Packing unit, in bag; for assembly height from 32 mm; for feed cable up to 16 mm <sup>2</sup>	0,030		
241 015 050	2	Splice-feed <b>50 A</b>	one-pole; complete; Packing unit, in bag; for assembly height from 27 mm; for feed cable up to 6 mm <sup>2</sup>	0,024		
241 015 090	3	End-feed <b>100 A</b>	one-pole; complete; Packing unit, in bag; for assembly height from 27 mm; for feed cable up to 16 mm <sup>2</sup>	0,029		
241 040 045	4	Feed cable	16 mm <sup>2</sup> 10,7 outer-Ø 1000 V black	Single-core flexible cable 1 m long One side titted with Terminal M6; 1 m long (other lengths on request)		
241 040 039			10 mm <sup>2</sup> 8,3 outer-Ø 1000 V black			
241 040 026			6 mm <sup>2</sup> 6,5 outer-Ø 1000 V black			
241 040 037			4 mm <sup>2</sup> 5,3 outer-Ø 1000 V black			
241 040 460			2,5 mm <sup>2</sup> 4,5 outer-Ø 1000 V black			
241 040 057			16 mm <sup>2</sup> 9,2 outer-Ø <b>Ground</b> green-yellow			
241 040 040			10 mm <sup>2</sup> 7,9 outer-Ø <b>Ground</b> green-yellow			
241 040 051			6 mm <sup>2</sup> 6,3 outer-Ø <b>Ground</b> green-yellow			
241 040 038	4 mm <sup>2</sup> 4,9 outer-Ø <b>Ground</b> green-yellow					
241 040 456	2,5 mm <sup>2</sup> 3,9 outer-Ø <b>Ground</b> green-yellow					
241 026 051	1	Housing	Assembly height 32 mm	Plastic-black	<b>only as spare</b>	0,007
241 015 051	2		Assembly height 27 mm			
241 014 010	3		Face closed			
251 015 000	1	Screw clamp	with asymmetric nut	M 6 with recessed hex-bolt SW 4	<b>only as spare</b>	0,023
241 015 052	2		with square nut			
251 022 020	3		pair of clips on one side			
506 006 002	5	Cable shoe	>1 - 2,5mm <sup>2</sup> cable	<b>For crimping requirements</b>	0,001	
506 006 006		DIN 46234	>2,5 - 6mm <sup>2</sup> cable			
506 006 010		E-Cu galv.	>6 - 10mm <sup>2</sup> cable			
506 006 016		For above feeding clamps	>10 - 16mm <sup>2</sup> cable			
518 501 010	6	Screwdriver Allen key 4 mm	For recessed hex-bolt M 6		0,036	

### Power-Feeds - Continued -

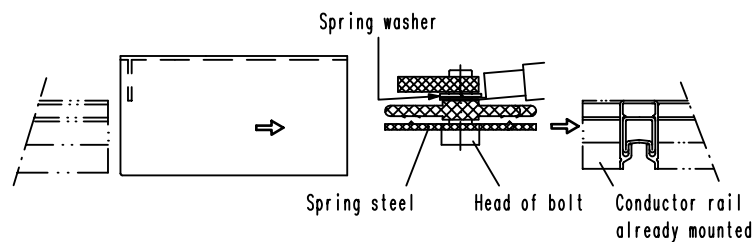
#### Technical Information

- The permissible continuous current depends on the feed cable (and the ambient temperature) :  
Splice-feed max. 100 A or 50 A; End-feed max. 100 A.
- Permissible ambient temperatures – 30°C to + 80°C.
- The feeds are suitable for the connection of the listed feed cables.

#### Planning Instructions

- Splice-feed 100 A :
  - Connection at the joint of the conductor rail (the rail connector is not required then).
  - Not to be used in bends.
  - Suitable for construction heights from 32 mm; for all conductor rails - also ground. Fig. 1
- Splice-feed 50 A:
  - Connection at the joint of the conductor rail (the rail connector is not required then).
  - Not to be used in bends.
  - Suitable for construction heights from 27 mm; for all conductor rails - also ground. Fig. 2
- End-feed 100 A:
  - Connection at the beginning and / or the end of the conductor rail installation.
  - Suitable for construction heights from 27 mm, for all conductor rails - also ground. Fig. 3

#### Installation Instructions

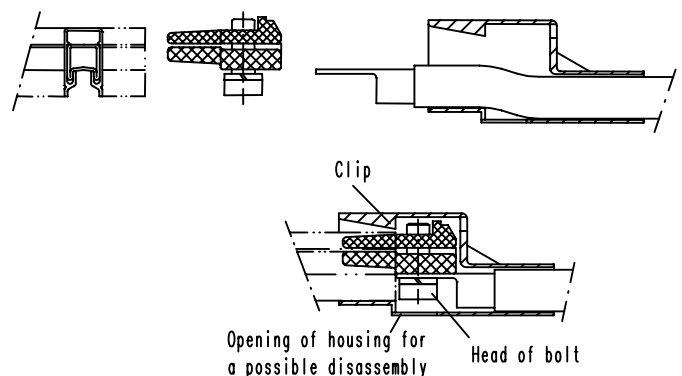


- Power-feed  
For max. 100 A :

- Loosely connect the feed cable to the screw clamp.
- Insert the screw clamp into the already installed conductor rail.
- Slide on the housing: take care that both sides of the insulating sheath are embraced.
- Clip the next conductor rail into the support clamp and move it towards the joint; slide together; the sides of the insulating sheath have to be embraced.
- Tighten the screw well.
- Be sure to install the feed cable so that it can follow the linear expansion of the rail; for the installation through webs (e.g. electric monorail tracks) provide grommet-protection.
- For more than 50 V: provide a separation of 3 mm or surface insulation to the grounded parts.
- Inspection at the end: Are both sides of both insulating sheaths embraced by the housing?

- End-feed 100 A:

- Lead the feed cable through the housing.
- Loosely connect the cable lug to the screw clamp.
- Plug the screw clamp into the end of the conductor rail.
- Tighten the screw well.
- Slide the housing on until the clip with the end of the thread snaps in.
- Be sure to install the feed cable in such a way that it can follow the linear expansion of the rail.
- For more than > 50 Volt : provide a separation of 3 mm or surface insulation to the grounded parts.



## Expansion

### General

Through fluctuations in the ambient temperature and / or currents or the heat generated, the length of the conductor rail installation changes. The hanger clamps allow a flawless sliding or linear movement of the conductor rails.

Fixing points arrest the conductor rails at certain points, thus controlling any linear displacement.

**Linear installations** up to a length of 60 m require no special expansion components, only a centered fixed point is to be installed.

**All other installations** require controlled expansion points :

- Linear sections of more than 60 m.
- Branched installations - e.g. electric monorail - with bends, switches, lift stations,

### Building- and / or track expansion joints.

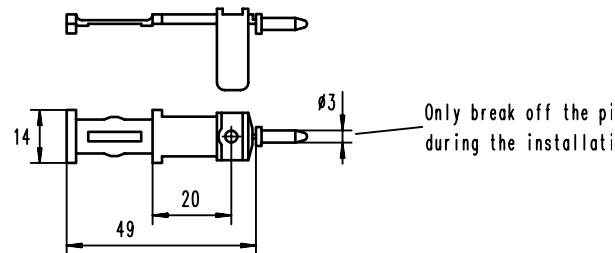
The following expansion components are used :

- Fixing point clip** in conjunction with a hanger clamp arrests the conductor rail, usually centered between two expansion points, for radii, proceeding or following the bend, for counter-directed bends the fixing point clip is to be installed in the center of the bend.  
Remark : Transitions at switches and lift sections are in part constructed as fixing points.
- Expansion bridge** for linear expansions of the conductor rail up to 25 mm. Installation on the joint of the rail. Electrically the expansion gap is bridged by a highly flexible cable designed for current at most 50 A. This is usually sufficient for branched installations with multiple feeds. If more than 50 A are required bridging feeds are to be located to the left and right of the nearest rail joint and connected by a cable.
- Expansion rails** for linear expansions of the conductor rail up to 25 mm, 50 mm or 75 mm. Shipped ready to be installed; with electric bridging of the expansion gap by a 6 mm<sup>2</sup> cable for max. 50 A. Is the expansion gap to be bridged with more than 6 mm<sup>2</sup>, feeds are to be installed to the left and right with a bridging cable.
- Separation **for electric interruptions. They also compensate for the linear expansion of the conductor rail up to 10 mm. If and when the separation point is fed electrically depends on its purpose - refer to electric separation. Observe the different assembly heights.**

**Apart from a good planning of the conductor rail installation, a correct and orderly installation is indispensable for the dependable operation and this not only for standard installations but also for extensively branched circuits - or for high travelling speeds, extreme fluctuations of temperature etc.**

*Because of our substantial experiences we are happy to be of assistance to you in the planning and suggest to have the installation carried out by our trained personnel - not in the least to guarantee the warranty on the proper function of our components or our FABA 100 system.*

### Fixed Point



Order-No.	Identification		Weight
241 010 006	Fixed-point clip	one-pole; Plastic, one-piece, red	0,002

### Technical Information

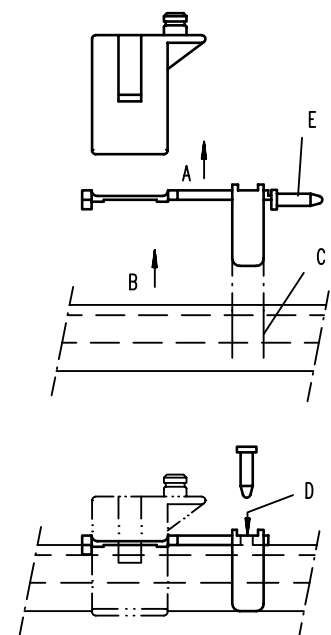
- Permissible continuous ambient temperatures – 30°C to + 80°C.
- For all conductor rails - also ground.
- The fixing-point clip in conjunction with one hanger clamp (all types) holds the metal rail as well as the insulating sheath in the longitudinal direction.
- To both sides can the conductor rail expand or contract - sliding through the remaining hanger clamps - in both directions.

### Planning Instructions

- Location of a fixing point :
  - In straight installations of up to 60 m in length; in the center.
  - Fundamentally between to expansion points / -joints; generally centered.
  - Also refer to expansion bridges, expansion rails and separation caps.
  - For bends immediately preceding or following, fixing in the center for counter-directional bends.
- The fixing-point clip is not remountable / not reusable.

### Installation Instructions

- Important ! The contact rail, which should be fixed with the fixed point clip, may not yet be connected with the ones already mounted - therefore, **without butt joint connector there**, but take account of appropriate spacing (screwable = 10 mm, pluggable = 1 mm).
- The contact rails already mounted must be and must remain aligned absolutely correctly in the lengthwise direction – for example, to the next expansion gap – which means that **these rails do not move** during the fixed point installation. If applicable, mark exact position (with felt pen).
- The arrangement of the fixed point clip is made within a hanger clamp:
  - Insert the fixed point clip into the hanger clamp – Arrow A.
  - Insert contact rail – Arrow B, also in other hanger clamps – with space to already assembly rail: with plug connectors, screwable = 10 mm, pluggable = 1 mm.
  - Mark the location of the fixing-point clip with a felt pen on the insulating sheath - refer to C.
  - Remove the rail from the hanger clamp, locate the fixing-point clip corresponding with the marking and use it as a drill template.
  - **Attention! Do not drill through the surface of the conductor.**
  - Break off the sharpened pin - refer to E - and tap it through the hole completely.
  - Take the conductor rail - with the pinned fixing clip – installed on the conductor rail and
  - Solidly press the conductor rail into the hanger clamp so that it audibly snaps into place.
- If - on exceptional occasions - a disassembly / correction should be required, a new fixing point clip is to be used; remove the fixing-point clip, again insert the pin (as protection against contact).  
Install the new fixing-point clip - perhaps to the other side - as described.





### Expansion connector

Abb. 1

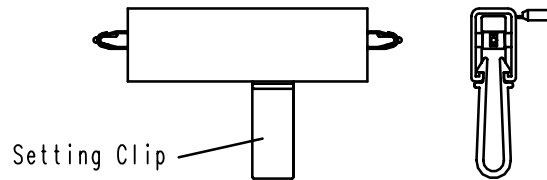
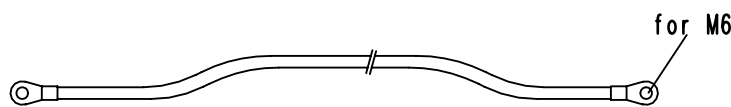


Fig. 2



Order No.	Fig.	Identification		Weight	
241 040 513	1	Expansion unit without cable till 50 A	For all building heights	With built-in spring contacts; Single-pole; Packaging unit, in bags	0.014
		Setting Clip	Included	Sets air gap for ambient expansion	
251 040 093	2	Bridging cable for above 50 A (see below)	6mm <sup>2</sup> , Outer dia. 7 mm, 1000 V black phase	Single-wire; halogen free, highly flexible; Cable shoe for M6 on both sides; 1600 mm long	0.178
251 040 094	2		6mm <sup>2</sup> , Outer dia. 6,5 mm, ground green-yellow PE	(Other lengths on request)	0.134

### Technical Information

- Allowable ambient temperatures - 30 °C to + 80 °C.
- The expansion, Fig. 1, is designed for an allowable continuous current of 50 Ampere at 35 °C ambient temperature. With higher temperatures, reduction in compliance with List IS 100 A Table 3 = Parallel arm slider.
- Bridging line will be required if the current transmission is not adequate with the expansion (see Planning Information). Allowable continuous currents and reduction through ambient temperature in compliance with VDE.

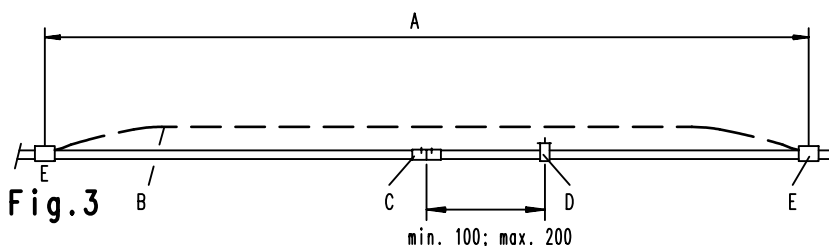
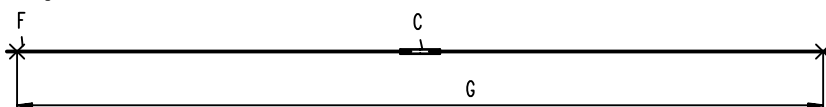


Fig. 3

- A = Spacing of the feeders for the bridging cable = 1500 mm
- B = Bridging cable
- C = Expansion (Expansion gap 2 to 27 mm between the rails)
- D = Hanger clamp
- E = Feed clamp : For bridging line 6 mm<sup>2</sup> = 50 Ampere
- F = Fixed point/Fixed point clip
- G = Length of the expansion stretch

Fig. 4



### Expansion – Continued –

#### Planning Information

- The expansion is for all conductor rails- including the ground
- For changes in the length of the conductor rail up to 25 mm.
- Arrangement of the expansion :
  - Only in straight stretches
  - Not in curves
  - In general, between rail joints
  - In principle, between two fixed points; in general, in the middle of it
  - Otherwise, see also Instructions on Expansion, Page 12.
- The expansion gap will be bridged electrically (see Technical Information as well) :
  - Up to 50 Ampere through the spring contacts in the housing
  - In case of higher currents, a bridging line is to be foreseen additionally.
- Maximum length of expansion stretch G and/or distance from fixed points F; see Fig. 4 and adjacent tables : The max. possible length depends upon the difference occurring in the ambient temperature and the power transmitted or heat generated thereby.

		Maximum allowable length of expansion stretch G [m]							
		Temperature Difference [K]							
		10	20	30	40	50	60	70	80
<b>FABA 40</b>	100 %	42	33	28	24	21	18	16	15
	60 %	56	42	33	28	24	21	18	16
	40 %	60	56	42	33	28	24	21	18
	<b>Ground</b>	60	60	56	42	33	28	24	21
<b>FABA 100</b>	100 %	31	25	21	18	16	14	12	11
	60 %	42	31	25	21	18	16	14	12
	40 %	60	42	31	25	21	18	16	14
	<b>Ground</b>	60	60	42	31	25	21	18	16

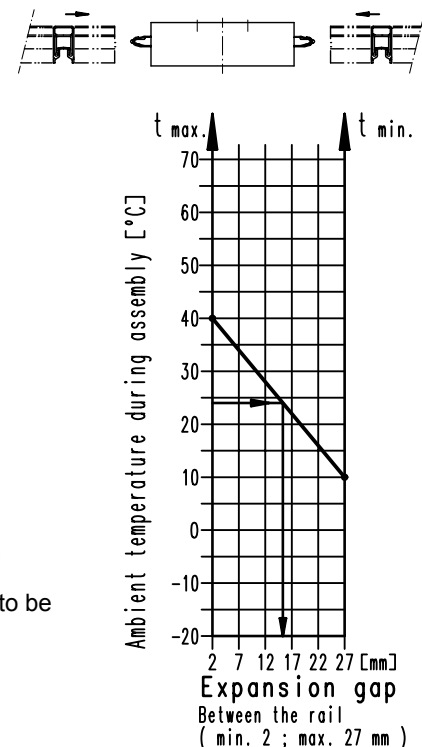
Note : Expansion stretch G amounts to max. 60 m in every case

**Example:** Possible ambient temperature max. + 50 °C, min. – 10 °C; The resulting temperature difference = 60 K [Kelvin]; for FABA 100 (at, for example, 60 % ED or power utilisation), in compliance with the table : permissible length of the expansion stretch is G = max. 16 m.

#### Assembly Instructions

- Insert both rails (ends deburred) in housing up to the stop point.
- Drill through insulating sleeve and upper strip of the metal rail with 3 mm drill bit through existing boring in housing.
- Pull expansion from the rails, deburr and clean in the metal rails.
- Slide rails into expansion to stop, break pins from housing and press completely into the borings. Rails must be able to pull apart and push together with low force.
- If additional bridging lines are necessary, the rails must not be restricted in their function.
- One support point clamp is necessary on one side at an interval of min. 100, max. 200 mm
- Set expansion gap (distance between the rails) :
  - In accordance with the ambient temperature at the time of installation
  - Expansion gap in accordance with diagram
  - Example:** Possible ambient temperature max. + 40°C, min. + 10°C; Mark points on diagram and join with a line; Ambient temperature during assembly = + 24°C, expansion gap to be set ca. 15 mm.
  - Important** Do not change the expansion gap during the following assembly work !

Fig 8



### Expansion-Rail

Fig. 1

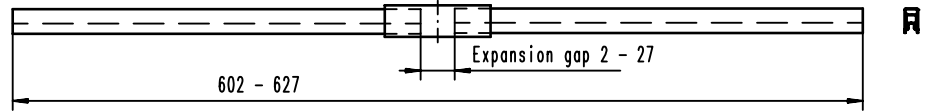


Fig. 2

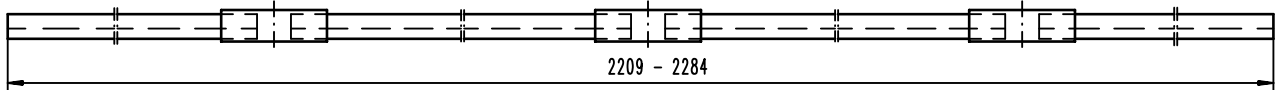
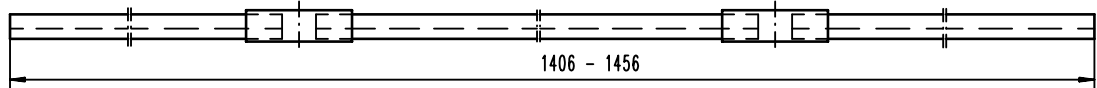
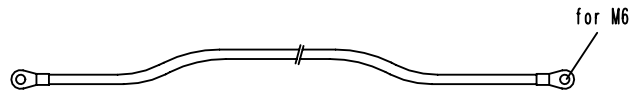


Fig. 3

Fig. 4

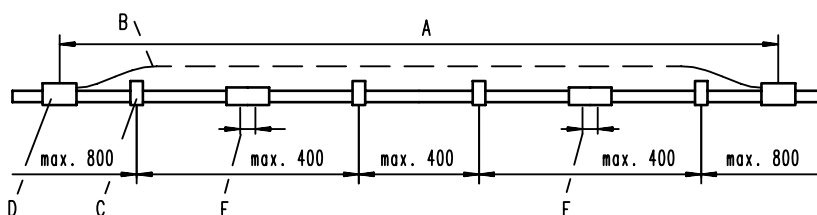


Order-No.	Fig.	Identification	Expansion	Rail-isolation			Weight
211 010 115	1	Expansion-rail	25 mm	Standard	Orange	one-pole; Height 27 mm	0,186
211 010 116				<b>Ground</b> Green-yellow	Metal rail, copper		
211 010 121				Heat-resistant	Orange	Ready to install	0,186
211 010 122				<b>Ground</b> yellow with green stripe	0,186		
211 010 117	2	Expansion-rail	50 mm	Standard	Orange	one-pole; Height 27 mm	0,426
211 010 118				<b>Ground</b> yellow with green stripe	Metal rail, copper		
211 010 123				Heat-resistant	Orange	Ready to install	0,426
211 010 124				<b>Ground</b> yellow with green stripe	0,426		
211 010 119	3	Expansion-rail	75 mm	Standard	Orange	one-pole; Height 27 mm	0,666
211 010 120				<b>Ground</b> yellow with green stripe	Metal rail, copper		
211 010 125				Heat-resistant	Orange	Ready to install	0,666
211 010 126				<b>Ground</b> yellow with green stripe	0,666		
251 040 099	4	Bridging-cable	1000 mm long	6 mm <sup>2</sup> , outer-∅ 6,5 , 1 kV, black		Single core flexible	0,090
251 040 100			For fig. 1	6 mm <sup>2</sup> , outer-∅ 6,3 <b>Ground</b> , green yellow			
251 040 093			1600 mm long	6 mm <sup>2</sup> , outer-∅ 6,5 , 1 kV, black		Both sides	0,178
251 040 094			For fig. 2	6 mm <sup>2</sup> , outer-∅ 6,3 <b>Ground</b> , green yellow			
251 040 097			2450 mm long	6 mm <sup>2</sup> , outer-∅ 6,5 , 1 kV, black		Cable lug for M6	0,268
251 040 098			For fig. 3	6 mm <sup>2</sup> , outer-∅ 6,3 <b>Ground</b> , green yellow			

### Technical Information :

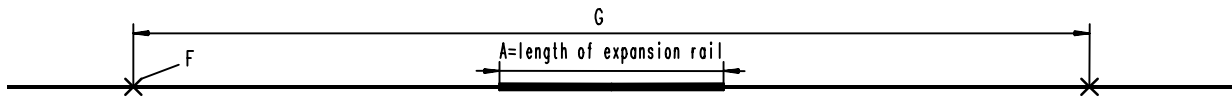
- Expansion rail fig. 1 to 3 suitable for FABA 40 and FABA 100; permissible continuous current 50 A, reduction by ambient temperature is the same as the conductor rail.
- Expansion rail with additional bridging cable : refer to fig. 5 (B); application using FABA 100; when continuous current of 100 A is required, reduction by ambient temperature is the same as the conductor rail. Each expansion gap is bridged by one highly flexible cable each, 6 mm<sup>2</sup>.

Fig. 5



- A = Length of the expansion rail
- B = Bridging cable
- C = Hanger clamp
- D = Feed clamp : 50 A for height 27 mm
- E = Expansion gap 2-27 mm, measured between rail ends

### Expansion-Rail - Continuation -



#### Planning Instructions

- Application also in the area of building- or rail expansion joints
- Also suitable for assembly heights 32 and 40 mm
- For all conductor rails - also ground.
- For fluctuations in length of the conductor rail of 25 mm, 50 mm or 75 mm.
- Max. length of the expansion distance G or separation of the fixing points
  - If the expansion rail is exclusively used to compensate building- or rail expansion joints, a fixing point is located immediately to the right and left next to the expansion rail.
  - Permiss. max. length if expansion distance G [m]

#### Example:

Possible ambient temperature max. + 40 °C, min. + 10 °C;  
 Resulting temperature difference = 30 K (Kelvin);  
 Then, according to the table, the power utilization and use of the expansion rail is 25 mm for FABA 40, for 100 % DC:  
 Expansion distance G = max. 35 m.

	loading Duty cycle	expansion rail	Maximum allowable length of expansion stretch G [m]							
			Temperature Difference [K]							
			10	20	30	40	50	60	70	80
FABA 40	100 %	25 mm	52	42	35	30	26	23	21	19
		50 mm	60	60	60	59	52	46	42	38
		75 mm	60	60	60	60	60	60	60	60
	60 %	25 mm	60	52	42	35	30	26	23	21
		50 mm	60	60	60	60	60	52	46	42
		75 mm	60	60	60	60	60	60	60	60
	40 %	25 mm	60	60	52	42	35	30	26	23
		50 mm	60	60	60	60	60	60	52	46
		75 mm	60	60	60	60	60	60	60	60
	Ground	25 mm	60	60	60	52	42	35	30	26
		50 mm	60	60	60	60	60	60	60	52
		75 mm	60	60	60	60	60	60	60	60
FABA 100	100 %	25 mm	39	31	26	22	19	17	15	14
		50 mm	60	60	52	44	38	34	30	28
		75 mm	60	60	60	60	57	51	45	42
	60 %	25 mm	52	39	31	26	22	19	17	15
		50 mm	60	60	60	52	44	38	34	30
		75 mm	60	60	60	60	60	57	51	45
	40 %	25 mm	60	52	39	31	26	22	19	17
		50 mm	60	60	60	60	52	44	38	34
		75 mm	60	60	60	60	60	60	57	51
	Ground	25 mm	60	60	52	39	31	26	22	19
		50 mm	60	60	60	60	60	52	44	38
		75 mm	60	60	60	60	60	60	60	57

Remark: The expansion distance G is in any case 60 m at most.

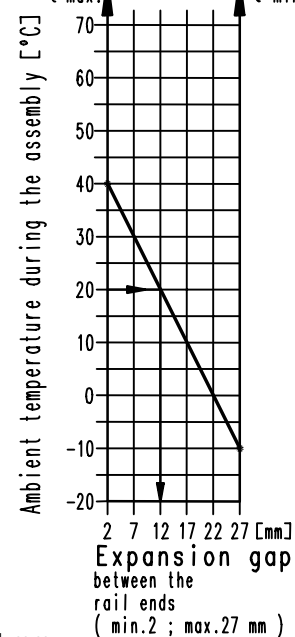
#### Installation Instructions

- Locate hanger clamps; separation to one another max. 400 mm, to others, max. 800 mm as usual (refer to fig. 5).
- When the additional bridging cable is being installed :
  - Install in a manner as not to impede the linear movement.
  - Install the joint-feeds D.
- Used for building- or rail expansion :
  - locate the expansion rail centered to the expansion joint.
  - locate a fixing point / fixing-point clip immediately to the right and left of the expansion rail.
- Adjust the expansion gap (distance between the rail ends) :
  - Expansion rail according to fig.1 = max. 27 mm;
  - according to fig.2 = max. 54 mm (2x27 mm);
  - according to fig.3 = max. 81 mm (3x27 mm)
- For application according to c) : expansion gap should correspond with the building-, rail expansion joint.
- Expansion gap according to the diagram

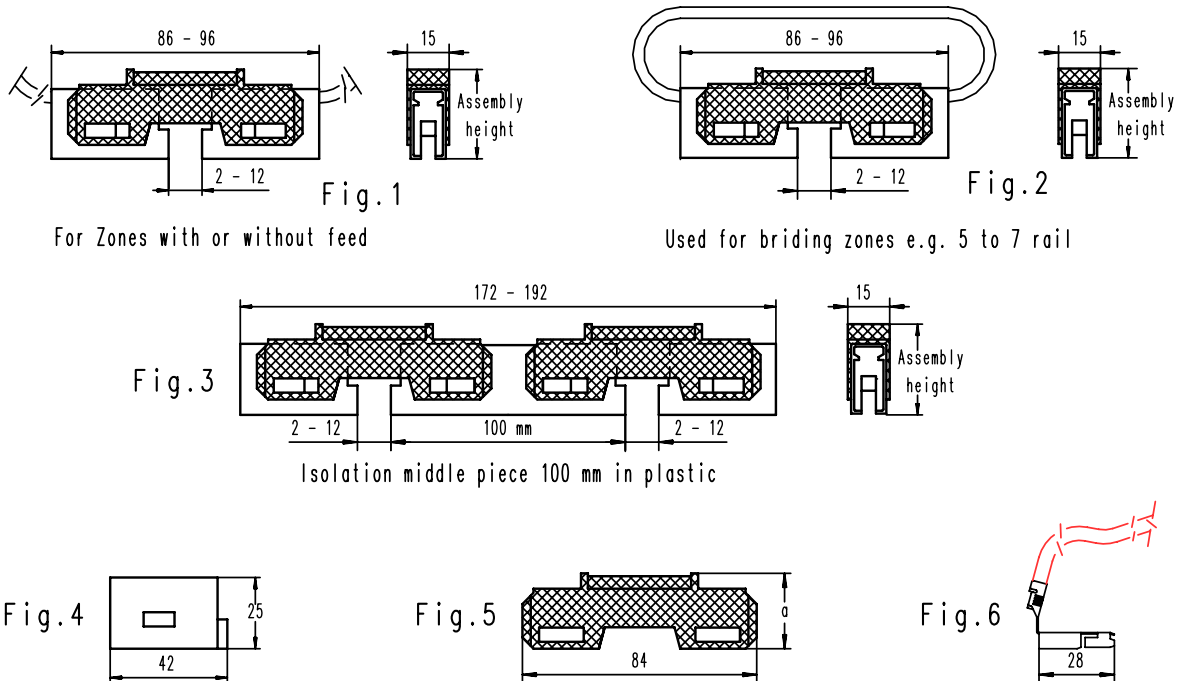
**Example:** possible ambient temperature max. + 40°C, min. - 10°C;  
 mark the points in the diagram and connect them with a straight line; temperature during installation = + 20°C;  
 expansion gap to be set = approx. 12 mm.

**Remark :** for the 50 mm expansion rail (fig. 2) = 2x12 mm, hence, a total of 24 mm;  
 for the 75 mm expansion rail (fig. 3) = 3x12 mm, hence, a total of 36 mm.

**Important:** Do not change the expansion gap for subsequent installation!



### Electrical-Separation



Order-No.	Fig.	Identification			Weight	
241 025 020	1	Separation without connecting cable	Assembly height 27	including : 2 plugs	one-pole;	0,020
241 025 021			Assembly height 32			0,021
241 025 022			Assembly height 40		packing unit, in bag;	0,023
241 025 026	1	with 1 connecting cable 1 m	Assembly height 27	1 cable plus 1 plug	1 connecting cable	0,050
241 025 027			Assembly height 32		complete in separate parts :	0,051
241 025 028			Assembly height 40			0,053
241 025 023	1	with 2 connecting cables 1 m	Assembly height 27	2 cables	2 pieces, separating caps	0,082
241 025 024			Assembly height 32		1 piece, holder	0,083
241 025 025			Assembly height 40			0,085
241 025 029	2	Separation with bridging cable	Assembly height 27	included : 1 bridging	as in fig. 1	0,030
241 025 030			Assembly height 32			0,031
241 025 031			Assembly height 40			0,033
241 025 040	3	Isolation 100 mm separation	Assembly height 27	included : 2 plugs	as in fig. 1, however : 2 separating caps, 2 holders, 1 insulating piece 84 long	0,040
241 025 041			Assembly height 32			0,042
241 025 042			Assembly height 40			0,046
241 022 220	4	Separating cap	Requires plug to assemble choose Fig.6	Plastic-black	<b>as spare only</b>	0,006
241 006 108	5	Holder	Assembly height a=27	Plastic-orange	<b>as spare only</b>	0,007
241 006 107			Assembly height a=32			0,009
241 006 106			Assembly height a=40			0,003
241 026 020	6	Plug	without cable			0,003
241 040 490	6	Connecting cable	2.5 mm <sup>2</sup> , outer-Ø 4.5 mm, 1 kV, single-core, flexible one side with plug; 1 m long (other lengths by request)		<b>as spare only</b>	0,032
241 040 495	6	Bridging	2.5 mm <sup>2</sup> , outer-Ø 4.5 mm, 1 kV, single-core, flexible; both sides with plug; 0.35 m long (other lengths by request)			0,015

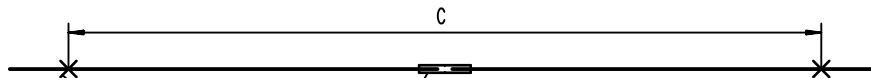
### Electrical-Separation - Continuation -

#### Technical Information

- For the electric separations of the conductor rail (control purposes and many others)
- The separations also compensate changes in length of the conductor rail.
- The separation, corresponding to fig. 1, may be fed on one or both sides.
- Permissible ambient temperatures – 30°C to + 80°C.
- The plugs, fig. 6, are not remountable (not reusable).

#### Planning Instructions

A = separation  
B = fixing point  
C = length of expansion distance



- For all conductor rails - for ground usually not required.
- For resting on the web of the conductor rail: observe the assembly height. The separation will not be specially fastened.
- Location :  
Principally at every point of the installation- also to be added later; only in straight sections, not in bends; fundamentally between 2 fixing points, generally in centered to both of these.
- Separation corresponding to fig. 1 and fig. 2 :
  - The separation of both metal rail ends is at max. 24 mm, it will be bridged by **one current collector**.
  - Depending on the purpose, by feed cables on one- or both sides, or by bridging to for example, to the next conductor rail.
  - The separation compensates changes in length of the conductor rail.
- Isolation separation corresponding to fig. 3 :
  - The center piece is of insulating material. The separation of the metal rail ends is at least 100, at most 120 mm, bridging by a current collector is impossible - while not desired.
  - The Isolation separation compensates changes in length of the conductor rail of up to 20 mm (2x10 mm).
- The possible max. length of the expansion distance C depends on the difference of the ambient temperatures present. Current heating remains neglected in this case, because the conductor rails will not be used for power transmission.

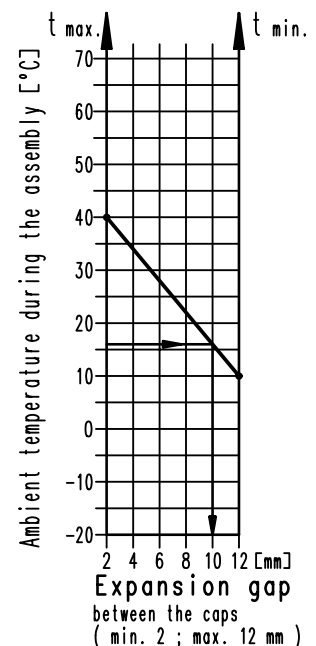
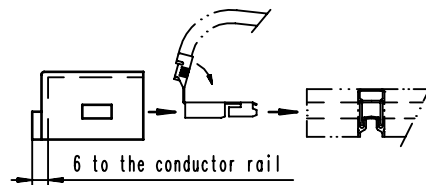
		Perm. Max. distance C in m							
		Difference Temperature [K]							
		10	20	30	40	50	60	70	80
<b>FABA 40</b>	Fig. 1 u. 2	60	42	28	21	17	14	12	10
	Fig. 3	60	60	56	42	34	28	24	20
<b>FABA 100</b>	Fig. 1 u. 2	60	M	E	T	E	R	S	
	Fig. 3	60	30	20	15	12	10	9	8
		60	60	40	30	24	20	18	16

Remark: The expansion distance C is in any case at max. 60 m.

**Example:** Possible ambient temperature of max. + 30 °C, min. – 10°C; hence, temperature difference = 40 K (Kelvin).  
According to the table, for FABA 100 the expansion distance C = max. 15 m according to fig. 1.

#### Installation Instructions

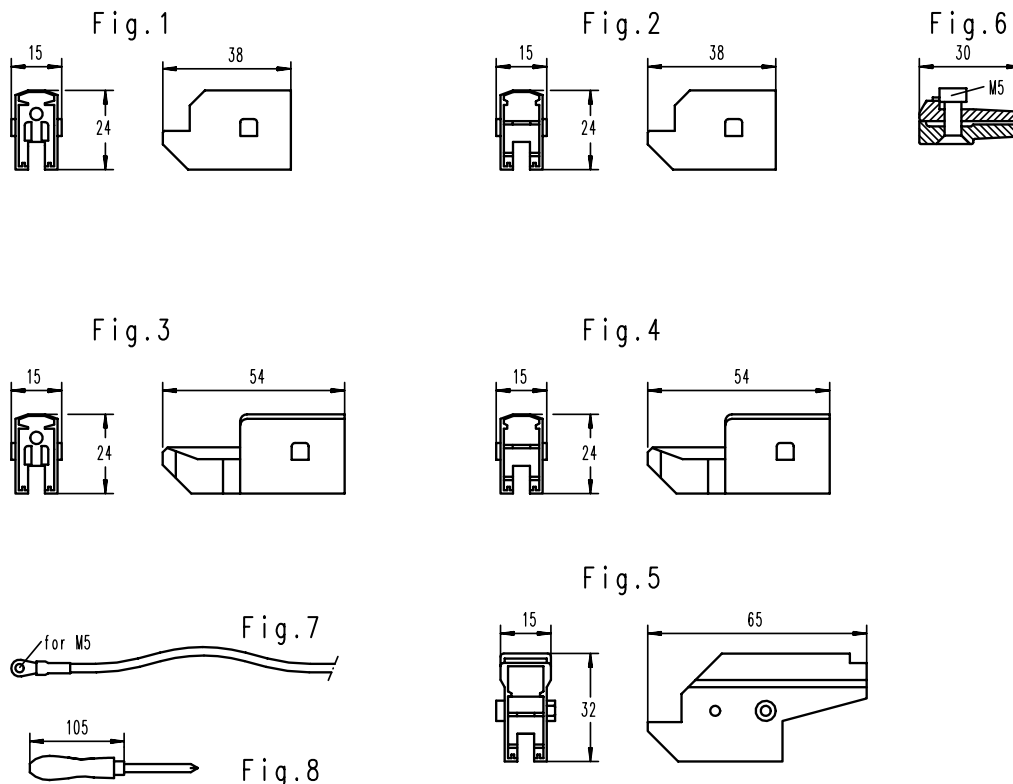
- Plug into the rail end to the stop - with or without cable.
  - Bend the end of the plug down - see arrow.
  - Push on the separation cap until the stop, both sides have to embrace the rail.
- Install the separation cap in the same manner to the other end of the rail.
- Clip the separating cap(s) into the web.
- If the separating cap touches the web of the rail, no additional hanger clamps will be required.
  - If the separation has no support, locate hanger clamps on one side, for isolation separation to the right and left: Separation min. 50, max. 100 mm.
- Adjust the expansion gap (separation between the caps) in correspondence with the graph: Separation = max. 12 mm, isolation separation = 24 mm (2x12).



**Example:** Possible ambient temperature max. + 40°C, min. + 10°C; mark the points in the graph and connect them with a straight line; temperature during the installation = + 16°C; expansion gap to be set approx. 10 mm.

**Important :** Do not change the expansion gap on subsequent installations!

### Transfer-Caps



Order-No.	Fig.	Identification				Weight	
			Feed possibility	Stagger of heights and sides			
241 017 045	1	Transfer cap	Without	Permiss. $\pm 2$ mm	plug-type; plastic-orange	0,004	
241 017 055	2 + 6	Transfer cap	With	Permiss. $\pm 2$ mm	screw-on type; packing unit, in bag; with clip, fig. 6 for cable up to 2.5 mm <sup>2</sup>	0,025	
241 017 048	3	Transfer cap	Without	Permiss. $\pm 4$ mm	plug-type; plastic-orange	0,005	
241 017 155	4 + 6	Transfer cap	With	Permiss. $\pm 4$ mm	screw-on type, packing unit, in bag; with clip, fig. 6 for cable up to 2.5 mm <sup>2</sup>	0,025	
241 015 025	5 + 6	Transfer cap	With	Permiss. $\pm 2$ mm	plug-type; packing unit, in bag; with clip, fig. 6 for cable up to 2.5 mm <sup>2</sup>	0,029	
241 040 415	7	Feed cable	6 mm <sup>2</sup>	outer- $\varnothing$ 6,5	1 kV black	single-core, halogen-free; flexible; 1 m long (other lengths on request)	0,110
241 040 412			4 mm <sup>2</sup>	outer- $\varnothing$ 5,3	1 kV black		
241 040 421			2,5 mm <sup>2</sup>	outer- $\varnothing$ 4,5	1 kV black		
241 040 417			6 mm <sup>2</sup>	outer- $\varnothing$ 6,3	<b>Ground</b> green yellow		
241 040 423			4 mm <sup>2</sup>	outer- $\varnothing$ 4,9	<b>Ground</b> green yellow		
241 040 408			2,5 mm <sup>2</sup>	outer- $\varnothing$ 3,9	<b>Ground</b> green yellow		0,036
241 017 035	2	Transfer cap	For feed clamp Fig. 5		plastic-orange	<b>as spare only</b>	0,004
241 017 038	4						0,005
241 017 060	5						
251 022 010	6	Screw-type feed clamp			with square nut	<b>as spare only</b>	0,021
518 502 000	8	Philips screwdriver			for countersunk screw M 5		0,088

### Transfer-Caps - Continuation -

#### Technical Information

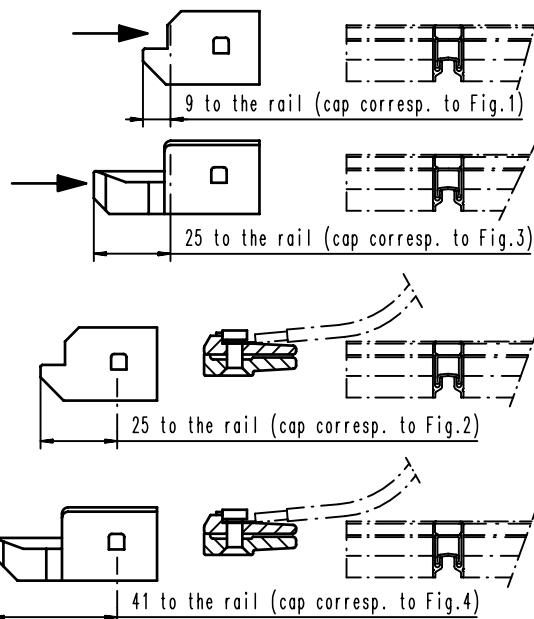
- Application : For mechanical separations of the conductor rail, e.g. on shunting stages, switches and similar.  
Also as separation cap on conductor rail ends - used also for ground.
- Conducting surfaces - selectively positioned down or sideways.
- Suitable for all conductor rails - also ground.
- The transfer caps without feed are not remountable / not reusable.
- Permissible ambient temperatures – 30°C to + 80°C.
- Refer to our special list IS 100 U for further transfer caps, for detailed data for transfers on switches, lift stations etc.

#### Planning Instructions

- Transfer caps corresponding to figs. 1 and 2 :  
For installations equipped with these transfer caps, only one current collector is required on the vehicle for each conductor rail - also for ground, because the collector bridges both ends of the metal rail.
- Transfer caps corresponding to figs. 3 and 4 :  
For installations equipped with these transfer caps, two current collectors are required on the carrier for each conducting rail - also for ground.
- Transfer caps corresponding to figs. 1 and 2:  
The permissible **air gap** between opposing caps is  
for a 90 degree-cut, max. 5 mm  
for a 45 degree-cut, max. 3 mm.
- Transfer caps corresponding to figs. 3 and 4 :  
The permissible **air gap** between opposing caps is  
for a 90 degree-cut, max. 8 mm  
for a 45 degree-cut, max. 5 mm.
- Hanger clamps are to be located behind the transfer caps :  
Distance to the cap, min. 20 mm, max. 50 mm.
- In bends/switches all caps can be fitted according to the cutting- or sliding angle.
- For the transfer caps not to move into the range of the metal rail end they must be secured with a fixed point.

#### Installation Instructions

- Metal rail and insulating sheath have to be of equal length.
- If the conductor rails have been shortened, they are to be de-burred very carefully, also on the inside.
- Install the caps without feed with light blows of the hammer.
- Caps with connection of one feed cable :
  - Loosely connect the cable with screw-type clamp.
  - Insert the screw-type clamp into the cap.
  - Locate both of them on the conductor rail.
  - The cap is adjustable towards the end of the rail by 3 mm.
  - Tighten the Philips-screw well.
- Inspect all caps :  
that both sides of the conductor rail sleeving are correctly secured.





### Current Collector EAS-L

Spring Pressure approx. 4 N

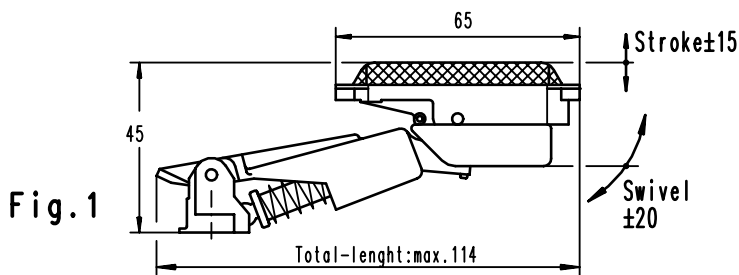


Fig. 1

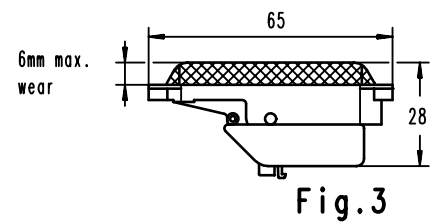


Fig. 3

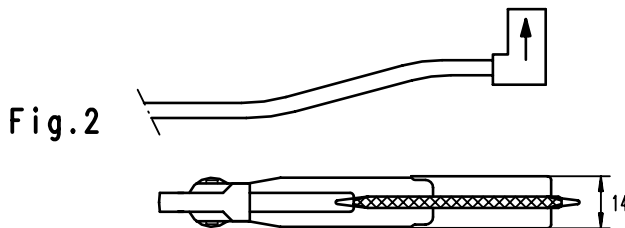


Fig. 2

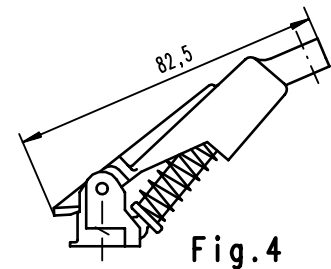


Fig. 4

### Standard Type

Order-No.	Fig.	Identification					Weight
241 035 030	1	One-arm current collector	20 A		one-pole; <b>Cu carbon shoe</b> ; without feed cable		0.029
241 035 056			Ground	yellow	All insulated parts in yellow		0.029
241 040 702	2	Feed cable 1 m long	20 A	black	1.5 mm <sup>2</sup> , outer-Ø 4.0,	single-core, halogen free highly flexible;	0.029
241 040 710			20 A	black	2.5 mm <sup>2</sup> , outer-Ø 4.5,	1000V; one side with DIN- plug;	0.038
241 040 712			Ground	green-yellow	2.5 mm <sup>2</sup> , outer-Ø 3,9,	(other lengths by request)	0.033
241 035 250	3	Head with pivot and shoe	20 A	black	Cu collector shoe; with spade connector		<i>as spare only</i>
241 035 265			Ground	yellow	and head (delivered only as unit)		0.014
251 035 001	4	Collector Body without Fig. 3	20 A	black	plastic; spring CrNi		<i>as spare only</i>
251 035 006			Ground	yellow			0.015

**Order base plate and bolting material for fastening the current collectors: separately (see page 25)**

### For Data Transfer

Order-No.	Fig.	Identification					Weight
241 035 057	1	Data-collector	one-pole;	<b>Silver</b> collector shoe;	<b>without feed cable</b>		0.028
			basic unit orange; head grey				
241 040 520	2	Shielded Feed cable	grey; 0.5 mm <sup>2</sup> ; outer-Ø 3.6; with shielding; single-core; highly flexible; one side with DIN-plug; 1 m long (other lengths by request)				0.020
241 035 266	3	Data head	grey; Silver collector shoe; with plug connection;				<i>as spare only</i>
251 035 001	4	Basic unit less head	standard design: plastic-orange				<i>as spare only</i>

**Order base plate and bolting material for fastening the current collectors: separately**

### Current Collector EAS-L - Continuation -

#### Technical Information

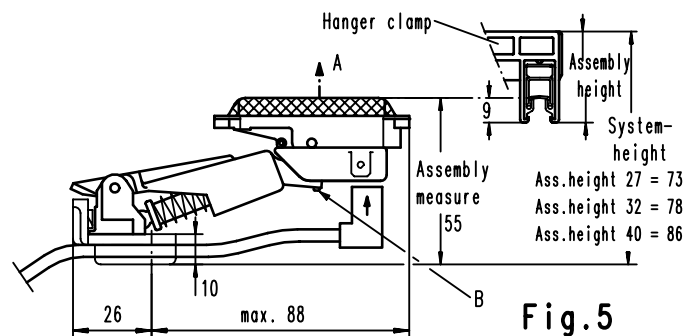
- a)
  - Permissible ambient temperatures – 30 °C to + 80 °C.
  - Feed cable to be specially ordered (use only cables of FABA).
  - Differently coloured feed cables on request.
  - The ground current collector has a larger joint at the head, so that the head or the collector carbon protrudes by 3 mm as compared to the others.
  - Suitable for travelling speeds up to 400 m/min, for back and forth operation, for installations with the rail conductor surface facing down or sideways, in bends from 500 mm radius.
- b) One-arm current collector of standard design :  
**Permissible continuous current 20 A till 40°C ambient temperature. For higher temperatures reduce according to table 3 in list IS 100 A.**
- c) One-arm sliding contact for data transmission :  
 Design of the connection line with shielding : single shielding.

#### Planning Instructions

- Pay special attention that the stroke of max.  $\pm 15$  mm and / or the permissible swivel of max.  $\pm 20$  mm is not surpassed on the total length of the line.
- **Install the console to the mobile equipment in such a way so that for installations with bends the head of the current collector is located at the center of support- / guide roller - see arrow A of fig. 5.**
- Usually only one collector is required per conductor rail, however, when using the data collector be certain to look at the special list IS 100 D "Data Transfer".

#### Installation Instructions

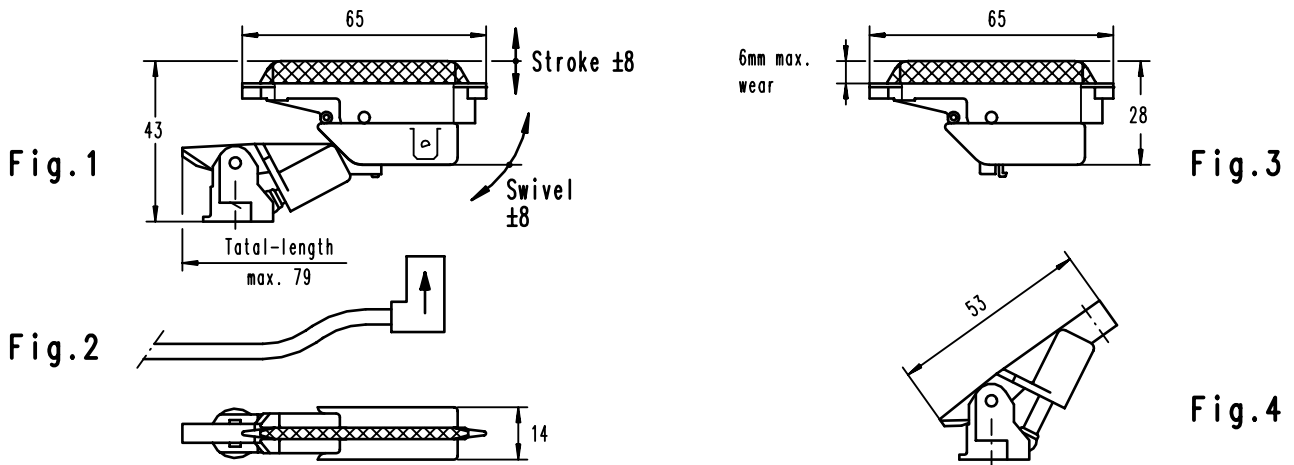
- a)
  - Mount the collector (turned out by approx. 30°) on the base plate, and swivel in (lug of the base plate secures the foot of the collector).
  - Ground collector can be mounted at every point.
- b) Connecting cable :
  - Use only FABA-cables to guarantee the proper operation of the current collector.
  - It is plugged directly - with care - onto the collector shoe within the head.
  - Insert only one cable through the opening of the base plate - do not twist the cable, it has to move unhindered.
  - The cable must not exert any stresses or torques on the head of the current collector.
  - If the cables have to be bundled, this should be done beyond the base plate - after the radius tapers off.
- c) Exchanging the head of the current collector :



Slightly push the clip on the end of the pivot - arrow B - slightly together with the fingers and pull off the head. When remounting, clip it into the arm.

### Current Collector EAS-K

Spring Pressure approx. 2,5 N



Order-No.	Fig.	Identification					Weight	
241 035 078	1	One-arm collector	10/16 A	black	one-pole;	Cu-collector shoe	without feed-cable	0.021
241 035 079		small	<b>Ground</b>	yellow		Cu-collector shoe		0.021
241 035 087		for data	orange/grey	Silver collector shoe		0.019		
241 040 397	2	Feed-cable	10 A	black	0.75 mm <sup>2</sup> , outer- $\varnothing$ 3.5	1000 V	single-core, highly	0.020
241 040 702		16 A	black	1.5 mm <sup>2</sup> , outer- $\varnothing$ 4.0	1000 V	flex., one side with	0,029	
241 040 712		1 m long	<b>Ground</b>	green-yellow	2.5 mm <sup>2</sup> , outer- $\varnothing$ 3,9		DIN-plug; other	0.033
241 040 520		for data	grey	0.5 mm <sup>2</sup> , outer- $\varnothing$ 3.6 with shield.		lengths by request	0.020	
241 035 250	3	Head small	<b>Ground</b>	black	Cu collector shoe; with plug connection		<i>as spare only</i>	0.014
241 035 265		for data	yellow	Cu collector shoe; with plug connection		0.014		
241 035 266		grey	Silver collector shoe; with plug connection		0.012			
251 035 020	4	Basic unit small	<b>Ground</b>	orange	plastic; spring CrNi		<i>as spare only</i>	0.007
251 035 021		Yellow			0.007			

**Order base plate and bolting material for fastening the current collectors: separate**

### Technical Information

- Permissible continuous current, depending on feed cable, 16 A or 10 A up to 40 °C ambient temperature. For higher temperatures reduce according to table 3 of list IS 100 A.
- Permissible ambient temperatures – 30 °C to + 80 °C.
- Suitable: for traveling speeds up to 200 m/min, for back and forth operation, for installations with the conductor surface facing down or sideways, with bends from 500 mm radius.
- Order feed cables separately (use only cables of FABA).
- Different colored feed cables by request.
- The ground current collector has a larger joint at the head, so that the head or the collector carbon protrudes by 3 mm as compared to the others.
- When using the data-collector pay attention to the special list IS 100 D "Data Transfer".

### Planning Instructions

- This current collector is extremely small, hence, its operating range is also especially small, please pay attention to the permissible lift of max.  $\pm 8$  mm and the permissible lateral movement of max.  $\pm 8$  mm.
- Apart from that observe the instructions for the one-arm current collector.

### Installation Instructions

Basically identical to the data on the "One-Arm Current Collector",  
**however:** assembly measurement 53 mm (instead of 55 mm),  
 height of system: for assembly height 27 = 71 mm;  
 for assembly height 32 = 76 mm; for assembly height 40 = 84 mm.

### Cleaning-Collector EAS-R

Spring Pressure approx. 4 N

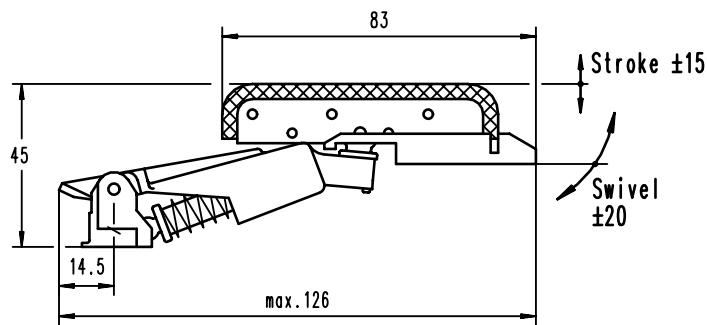


Fig. 1

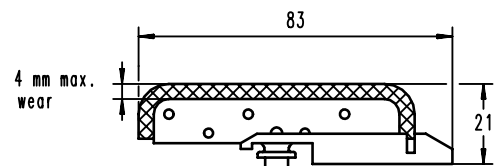
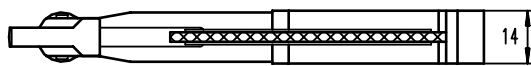


Fig. 2

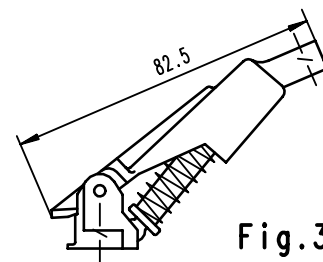


Fig. 3

Order-No.	Fig.	Identification		Weight
241 035 063	1	One-arm cleaning collector	one-pole; <b>with fibre pad;</b> <b>without connecting cable</b>	0,022
241 035 268	2	Cleaning head	plastic with fibre pad;	<b>as spare only</b> 0,007
251 035 001	3	Basic unit	plastic-orange; spring CrNi	<b>as spare only</b> 0,015
Order base plate with bolting material for fastening the current collectors: separately				

### Technical Information

- a) **Application:**
- in systems with rail collector surface facing down or sideways, in bends from 0,5 m radius;
  - also for ground conductor rail;
  - one cleaning collector per conductor rail;
  - in principal for all electric monorail installations;
  - otherwise also if data transfer has been planned or control commands are to be transferred;
  - required for the equalization of the rail conductor surface prior to the initial start-up;
  - for all installations, in which extreme dirt is to be expected, especially for deposits of non-conductive suspended particles (such as small fibres / fluff) for example.
- b) The collector particularly removes foreign coatings from the conductor surface; the fibre pad has a long lifetime, does not rust or splinter.
- c) The cleaning collector does not serve for the transfer of power and is therefore to be mounted separately on the mobile equipment.
- d) Permissible ambient temperatures – 30°C to + 80°C.
- e) Suitable for traveling speeds up to 200 m/min, for back and forth operation.

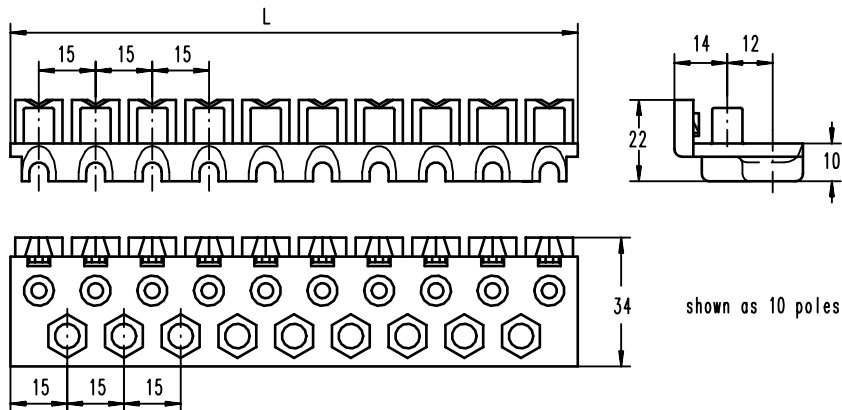
### Planning Instructions

- To assure a perfect contact, the complete installation has to be traversed with the cleaning collectors approx. 20 times before the initial start-up, following that in regular intervals only if fouling is to be expected.
- For the electric monorail it is sensible to mount it on the follower part of the carrier.
- The console or base plate for mounting the current collectors are to be fastened to the mobile equipment in such a way as to assure that in installations containing bends the head is in the center of the support- / guide roller.

### Installation Instructions

- a) Fundamentally identical to the data on the "One-Arm Current Collector".
- b) Mount the console and the base plate as usual - refer to base plate.
- c) The assembly measurement (with base plate) is 45 + 10 = 55 mm.
- d) Replacement of the cleaning head:
- Press the bolt of the joint slightly together (as is done for the one-arm collectors) and pull off the head.
  - Insert or clip on the spare head.

### Base-Plate for current-collector EAS-L / EAS-K



shown as 10 poles

Order-No.	Identification	Poles	Length L		Weight
241 036 053		1-	27		0,006
241 036 051		2-	29		0,009
241 036 025		3-	44		0,012
241 036 032		4-	59	One piece	0,015
241 036 029		5-	74		0,018
241 036 026		6-	89	Plastic orange	0,021
241 036 023		7-	104		0,024
241 036 020	Base plate	8-	120		0,027
241 036 024		9-	135	For conductor rail	0,031
241 036 060		10-	150	Center separation 15 mm	0,034
241 036 061		11-	164		0,038
241 036 062		12-	179		0,041
241 036 063		13-	194		0,045
241 036 064		14-	210		0,048
241 013 025	Screw-	to 8-	2 pieces each	Hex. screw M6 x 25,	0,022
241 013 027	material	to 13-	3 pieces each	Nut, washer, spring washer	0,033
241 013 028		14-	4 pieces	Unit packed in bag	0,044

### Technical Information

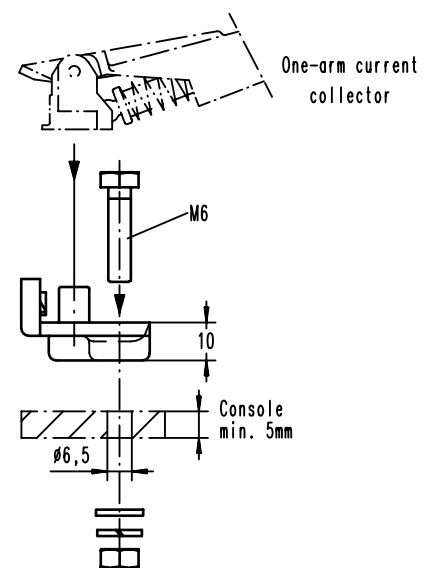
- For fastening to all one-arm current collectors.
- \* Permissible ambient temperatures – 30°C to + 80°C.

### Planning Instructions

- Pay attention to the stability of the console.
- The console will be shipped by request.
- Mount the console in such a manner to the mobile equipment that, for installations containing bends, the head of the current collector is located in the centre of the support- / guide roller.

### Installation Instructions

- Bolt the base plate to the console.
- Location of bolts :  
always use the outer holes if possible;  
spacing of holes 15 mm, each time located between the mountings of the collector.
- Align the base plate so that the current collectors to be inserted are in line with or centred to the conductor rails.  
Sliding holes in the console are advisable for this purpose.



### Current Collector PAS-K

Spring Pressure approx. 4 N

with spade socket 4.8x0.8 till 20A

with screw connection M4 till 30A

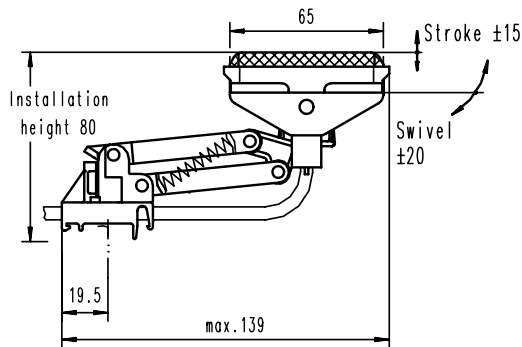


Fig. 1

with screw connection M4 till 50A

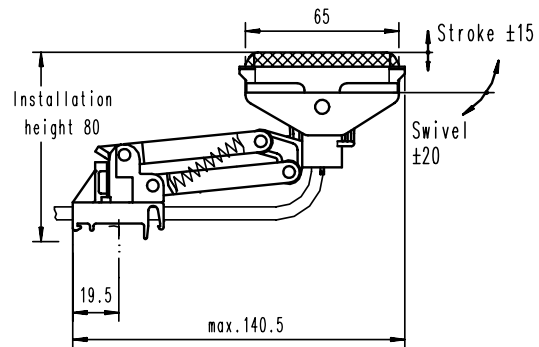


Fig. 2

### Current Collector PAS-L

Spring Pressure approx. 6 N

with spade socket 4.8x0.8 till 20A

with screw connection M4 till 30A

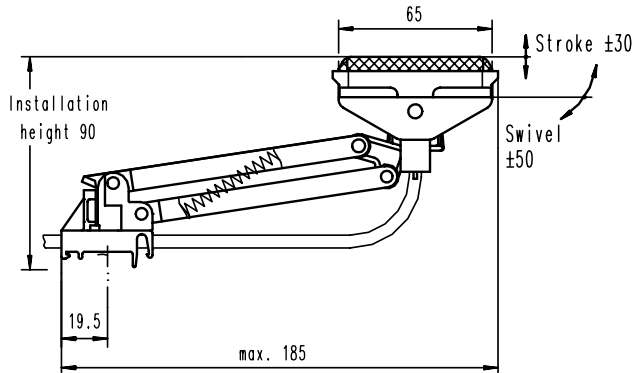


Fig. 3

with screw connection M4 till 50A

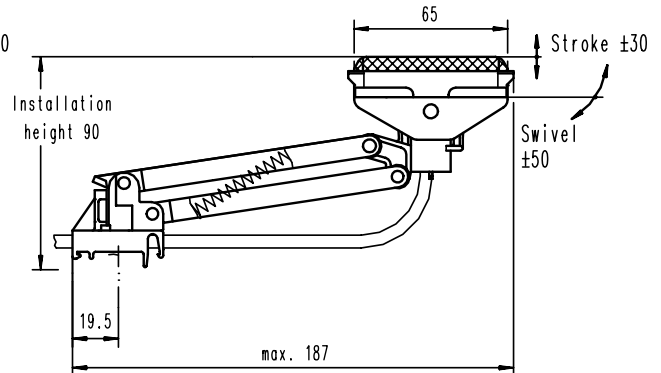


Fig. 4

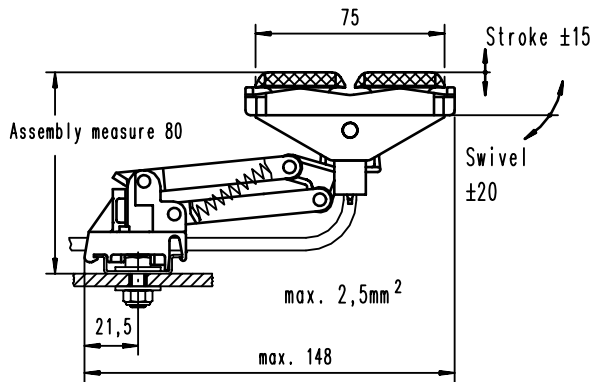
Order-No.	Fig	Identification				Weight	
241 035 325	1	Double-Arm		Spade	black head	1 pole;	0,040
241 035 326		Collector	Ground	Connection	yellow head and foot		0,040
241 035 155	1	Double-Arm		Screw	black head	Cu Shoe;	0,040
241 035 156		Collector	Ground	Connection M4	yellow head and foot		0,040
241 035 167	2	Double-Arm		Screw	black head	Plastic Body	0,040
241 035 168		Collector	Ground	Connection M4	yellow head and foot		0,040
241 035 331	3	Double-Arm	with	Spade	black head	CrNi-Spring	0,048
241 035 332		Collector	longer arm	Connection	yellow head and foot	Stainless steel	0,048
241 035 160	3	Double-Arm	with	Screw	black head	without cable	0,048
241 035 161		Collector	longer arm	Connection M4	yellow head and foot		0,048
241 035 163	4	Double-Arm	with	Screw	black head	without collector	0,048
241 035 164		Collector	longer arm	Connection M4	yellow head and foot	bracket	0,048
241 035 327	1			Spade	Body orange		0,040
241 035 157	1	Double Arm current collector		Connection	Head grey	with Silver Shoe	0,040
241 035 333	3	For Data Transmission		Connection M4	Body orange		0,048
241 035 162	3	with Longer Arm		Spade	Head grey	with Silver Shoe	0,048
				Connection			
				Connection M4			

### Continuation –

**Current Collector PAD-K**  
**Current Collector PAD-L**

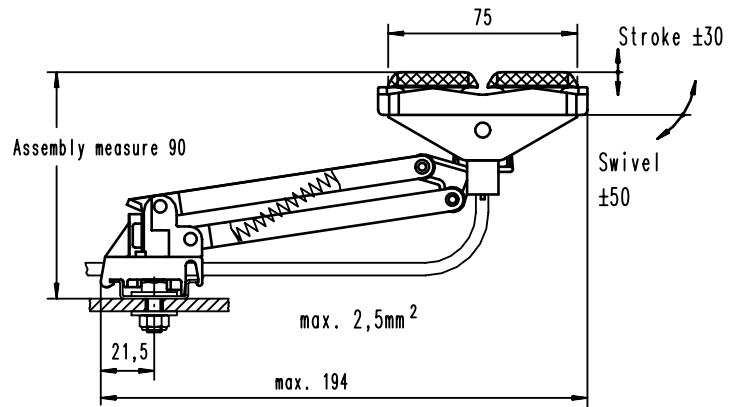
Spring Pressure approx. 4 N  
Spring Pressure approx. 6 N

with spade socket 4,8x0,8 till 20A



**Fig. 5**

with spade socket 4,8x0,8 till 20A



**Fig. 6**

Order-No.	Fig	Identification					Weight	
241 035 165	5	Double-Arm Collector	With two shoes	phase ground	Spade Connection	black yellow Head and Foot	Cu-collector shoe	0,038
241 035 166							Cu-collector shoe	0,038
241 035 140	6	Double-Arm Collector	With two shoes longer arm	phase ground	Spade Connection	black yellow Head and Foot	Cu-collector shoe	0,046
241 035 141							Cu-collector shoe	0,046

### Attention !

Systems with collectors with double long arms and pick-up guides have a larger installation measurement being 100 mm.

### Double-arm current collector

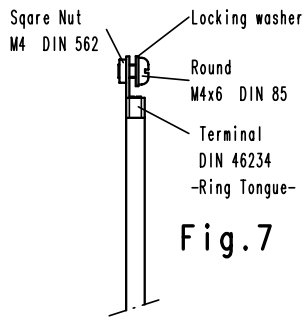


Fig. 7

Female terminal 4,8x0,8

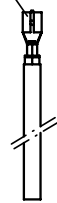


Fig. 8

### accessories – continuation –

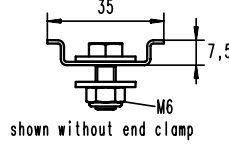


Fig. 9

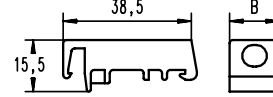


Fig. 10a

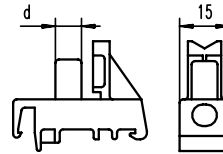


Fig. 10b

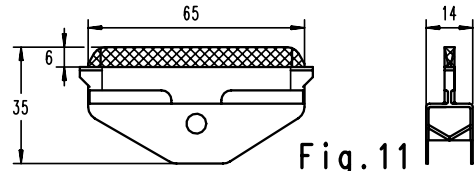
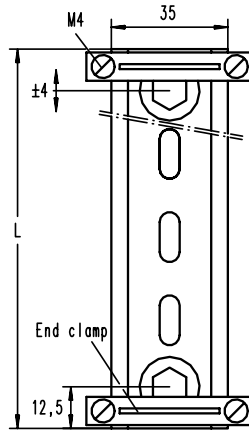


Fig. 11

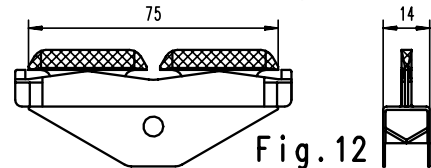


Fig. 12

Order No.	Fig.	Name				Weight	
241 040 011	7	Connection cable for screw connection (for collector Fig. 1, 2, 3, 4)	20 Amp.	black	1.5 mm <sup>2</sup> Outer -∅ 4.0	Single-wire; Halogen free; Highly flexible; 1000 V; One-end M4; 1 m long (other lengths on request)	0.030
241 040 013			30 Amp.		2.5 mm <sup>2</sup> Outer -∅ 4.5		0.040
241 040 014			40 Amp.		4 mm <sup>2</sup> Outer -∅ 6.0		0.080
241 040 016			50 Amp.		6 mm <sup>2</sup> Outer -∅ 7.5		0.120
241 040 012			<b>Ground</b>		2.5 mm <sup>2</sup> Outer -∅ 3,9		0.034
241 040 015			<b>Ground</b>		4 mm <sup>2</sup> Outer -∅ 4,9		0.056
241 040 017	<b>Ground</b>	6 mm <sup>2</sup> Outer -∅ 6,3	0.072				
241 040 018	7	Data connection cable for screw connection (for collector Fig. 1 and 3)			0.5 mm <sup>2</sup> Outer -∅ 3.6; with shielding; grey single-wire; highly flexible; one-sided M4 1 m long (other lengths on request)	0.022	
241 040 060	8	Connection cable for plug terminal (for collector Fig. 1,3,5,6)	20 Amp.	black	1.5 mm <sup>2</sup> Outer -∅ 4.0	Single-wire; highly flexible; 1000 V; One-end with DIN plug; 1 m long (otherwise, on request)	0.030
241 040 061			20 Amp.	black	2.5 mm <sup>2</sup> Outer -∅ 4.5		0.040
241 040 062			<b>PE</b>	green-yellow	2.5 mm <sup>2</sup> Outer -∅ 4.0		0.034
241 013 110	9	Support rail for holding collectors	2- pole		L = 75	For sliding contact rails Centre point spacing 15 mm; complete : with 2 end clamps and 2 attachment screws; Design, galv. steel Zn	0.056
241 013 111			3-/ 4-pole		L = 100		0.064
241 013 112			5-/ 6-pole		L = 125		0.072
241 013 113			7-/ 8-pole		L = 150		0.080
241 013 114			9-/10-pole		L = 200		0.095
241 013 115			11-/12-pole		L = 225		0.104
241 013 116			13-/14-pole		L = 250		0.112
241 013 117	9	Support rail	<b>Length L = 400 mm;</b> for any desired sliding contact rails centre spacing; Complete : With 2 end clamps and 2 attachment screws; Design, galv. steel Zn			0.160	
241 024 075	10 a	Spacer piece	One-piece made of plastic; Width B = Centre spacing minus 15; <b>State conductor rail centre spacing when ordering</b>			0.005	
251 035 055	10 b	Base plate	orange	One-piece made of plastic; diameter d = 8		<b>Only as spare</b>	0,006
251 035 056		Base plate	<b>Groud</b> yellow	One-piece made of plastic; diameter d = 6		<b>Only as spare</b>	0,006
241 035 321	11	Replacement head for plug connection (for collector Fig. 1 and 3)	<b>Groud</b>	orange	} Cu-sliding carbon contact; for plug connection 4.8 x 0.8 Silver-sliding carbon contact; with plug connection 4.8 x 0.8	<b>Only as spare</b>	0,017
241 035 322			<b>Data-</b>	yellow			0,017
241 035 323				grey			0,017
241 035 315	11	Replacement head for screw connection (for collector Fig. 1,2,3,4)	phase	black	} Cu-sliding carbon contact; for screw connection M4 Silver-sliding carbon contact; for screw connection M4	<b>Only as spare</b>	0,017
241 035 316			<b>Groud</b>	yellow			0,017
241 035 317			<b>Data-</b>	grey			0,017
241 035 420	12	Replacement head (for collector Fig. 5 and 6)	phase	black	Cu-sliding carbon contact; with plug connection 4.8 x 0.8	<b>Only as spare</b>	0,015
241 035 421			<b>Groud</b>	yellow			0,015



### Double-arm Current Collector

- Continuation -

#### Technical Information

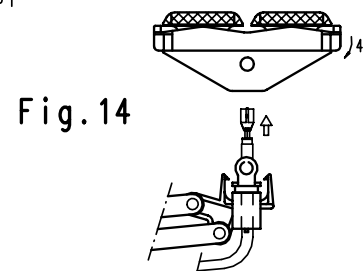
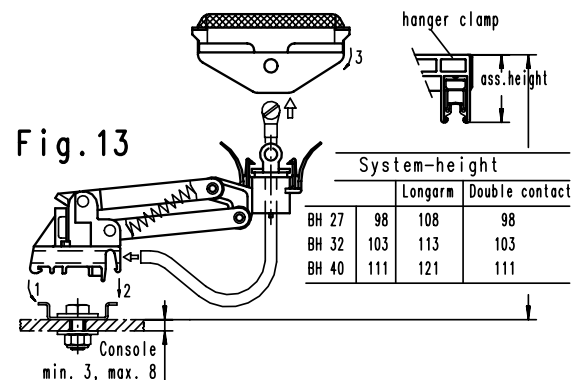
- Permissible Ambient temperature – 30°C to + 80°C.
  - Collector Cables to be ordered separately (use only special Faba cables).
  - Other colors on request.
  - Foot and head are self centering when disengaged from the conductor rail.
  - Ground Collector is 4 mm higher.
  - The head is spring loaded  $\pm 5$ .
  - Collector Cables must not be pulled taught.
  - Suitable For speeds up till 400 m/min. and back and forth motion.  
For systems where contact surface is facing sideways or down.  
For bends above 500 mm Radius.  
Suitable for 20 - 50 Amps at 40°C Ambient temperature depending on the correct cable see page 28.
- Allowable continuous current depends upon the connection line **20 A, 30 A, 40 A or 50 A** up to 40°C ambient temperature. At higher temperatures, reduction in compliance with Table 3 in List IS 100 A.
- Design with long arm :  
Preferred place of installation, for example, crane systems, meaning when longer lifting / longer swing is necessary.  
**Attention !** Installed dimension for systems with hopper : 100 mm.
- Design with double contact :  
Max. allowable continuous current **20 A** (otherwise as for b). Used preferably for control functions.
- Parallel arm slider for data transmission :  
Design of the connection line with shielding : single shielding.
- For sliding contact rail centre spacing larger than 15 mm, observe:
  - min. 30 mm is necessary, for example, when laying in moist areas / rooms or in the open air;
  - All parallel arm sliding contacts are suitable;
  - Do not install any raising / lowering hoppers in the system.

#### Planning Instructions

- It is essential that the stroke and swivel tolerances of the collector are held on the whole track system .
- Collector holder bracket are to be situated on carriers where bends exists so that the collector head is situated middle of the drive roller of the carrier .
- Normal practice is a one head collector for each conductor rail . Please see the special list IS 100 D for data transmission with collector .
- \* When rail centers of more than 15 mm are required :  
Use holder bracket 400 mm long (shorten to requirements);  
and use spacer Fig. 7 between each collector .

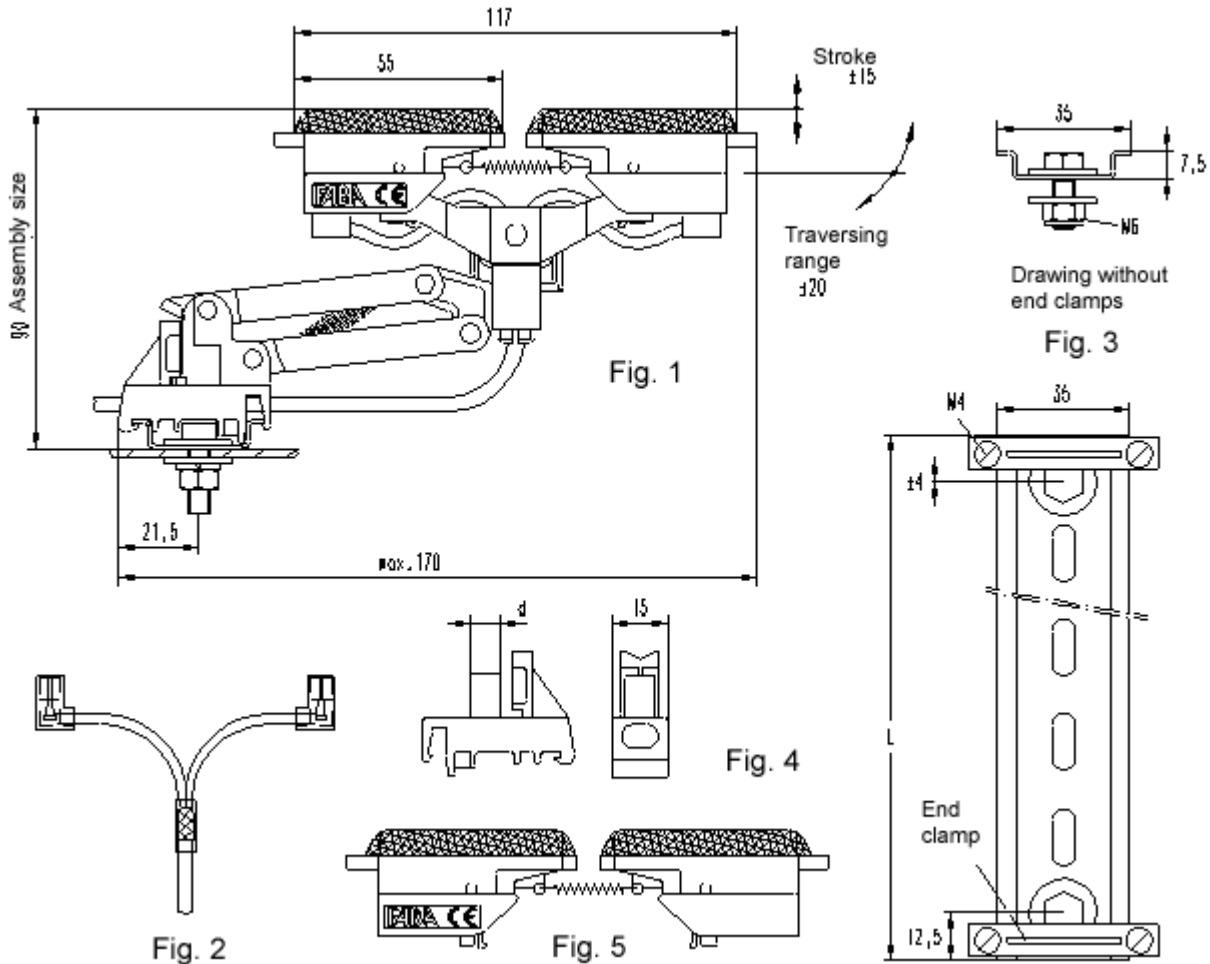
#### Installation Instructions

- Screw collector bracket on holder.
- Clip Collector base starting from the back of the collector with a turning motion onto the holding bracket for spacing more than 15 mm use appropriate number of spacers width 15 mm making sure collectors line up middle to the conductor rail. Make sure the ground collector (yellow head) is positioned in the ground conductor rail.
- Cable connection :
  - For reliable function use only Faba cables highly flexible function.
  - Cable connection screw-on type (Fig. 13)  
Pass the cable end without terminal through the top pivot then through the hole in the base section and connect. Tighten Cable with screw connection M4 on to collector shoe, making sure the tongue on the collector shoe is positioned between the ring terminal and locking washer.
  - Cable connection push on type (Fig. 14)  
Pass Cable through top pivot make sure female terminal fits secure on make terminal allow slag on cable for future Shoe change before securing cable.
  - Make sure cables are not twisted, the head must be allowed to pivot freely in all directions. Failure to do so will cause a bad function of the collector and cause excessive wear on collector shoes.
- Shoe change:
  - For fig. 13 : Press head down and hold. Tilt head backwards – arrow 3.
  - For fig. 14 : toward arm and pull off – arrow 4.



### Current collector PA DS-20

Spring Pressure approx. 7 N



Order No.	Fig.	Identification				Weight
241 035 710 241 035 711	1	Parallel arm, double contact curr. coll.	PE	Plug connection	Head, black Head + base, yellow	Cu-collector shoe  0.055 0.055
241 040 077	2	Connecting cable	20 A	black	2.5 mm <sup>2</sup> outer-∅ 4,5	0.042
241 040 085			PE	green-yellow	2.5 mm <sup>2</sup> outer-∅ 3,9	0.036
241 013 111 241 013 112 241 013 113 241 013 114	3	Supporting rail		3-/ 4-poles 5-/ 6-poles 7-/ 8-poles 9-/10-poles	Length L = 100 L = 125 L = 150 L = 200	Single-core; halogenfree, highly-flexible; 1000 V; 1 m long (Special designs on request) Centre distance: 15 mm; complete: with 2 end clamps and 2 fastening screws
251 035 055 251 035 056	4	Base plate Base plate	PE	orange yellow	one piece, plastic, ∅ d = 8 one piece, plastic, ∅ d = 6	0.006 0.006 <i>Only if repl.</i>
241 035 705 241 035 706	5	2 replacement heads for plug connection	PE	black yellow	Cu-collector shoe; for plug connection 6.3 x 0.8	0.028 0.028 <i>Only if repl.</i>

### Current collector PA DS-20 – Continuation –

#### Technical information

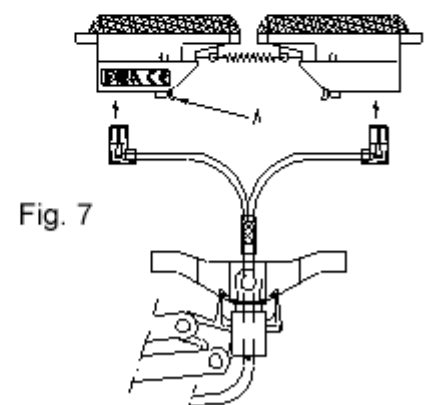
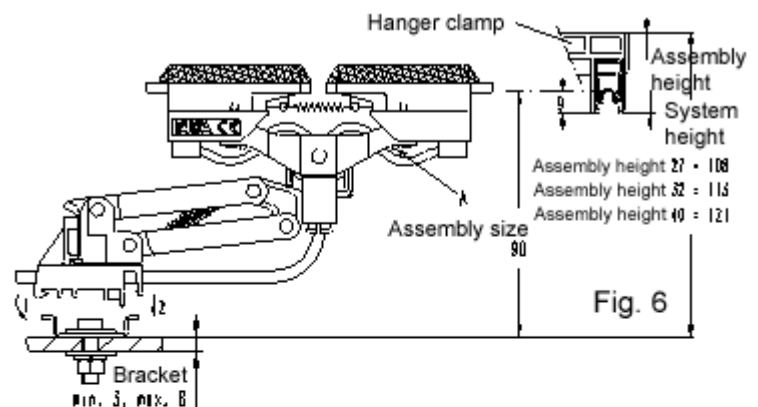
- a)
  - To be preferred for control tasks, since 2 separate current collector heads are available.
  - Permissible ambient temperatures:  $-30\text{ °C}$  up to  $+80\text{ °C}$ .
  - Order connecting cable separately (use products by Fahrleitungsbau only).
  - Connecting cables of different colours on request.
  - Head and base have a centring, i.e. in extended/pulled off position, the current collectors including the head are in a „straight“ position.
  - PE-current collectors are 3 mm higher in the extended/pulled off position.
  - The heads are spring-mounted and can be inclined by  $\pm 5^\circ$ .
  - The installation of the connecting cable does not (or hardly) influence the functioning of the collector shoe/the head.
  - Suitable for travelling speeds up to 400 m/min, both for unidirectional and reversing operation, for installations with conductor rail surfaces facing down or sideways, with bends of radii larger than 500 mm, for conductor rail separations with a displacement of up to 4mm, for the use of pick up guides.
- b) Permissible continuous current of the connecting line **20 A** up to an ambient temperature of  $40\text{ °C}$ . If both heads continuously fit, suitable for max. **40 A**, for higher current intensities, please order special cable. For higher temperatures, reduction according to table 3 in list IS 100 A.
- c) Please consider the following for conductor rail distances larger than 15 mm:
  - min. 30 mm is required for installations in damp spaces or for outdoor installations;
  - do not install pick up guides in such systems.

#### Planning instructions

- Strictly ensure that the stroke and/or the permissible traversing range is not exceeded regarding the entire system.
- Install the supporting rail to the mobile equipment in such a way that in case of systems with bends, the collector heads are located in the centre of the supporting/guiding roll, if possible.
- Usually, **only one current collector (with one head) per conductor rail** is required, if, however, the current collectors are used for data transfer, refer to special list IS 100 D „Data Transfer“.

#### Installation instructions

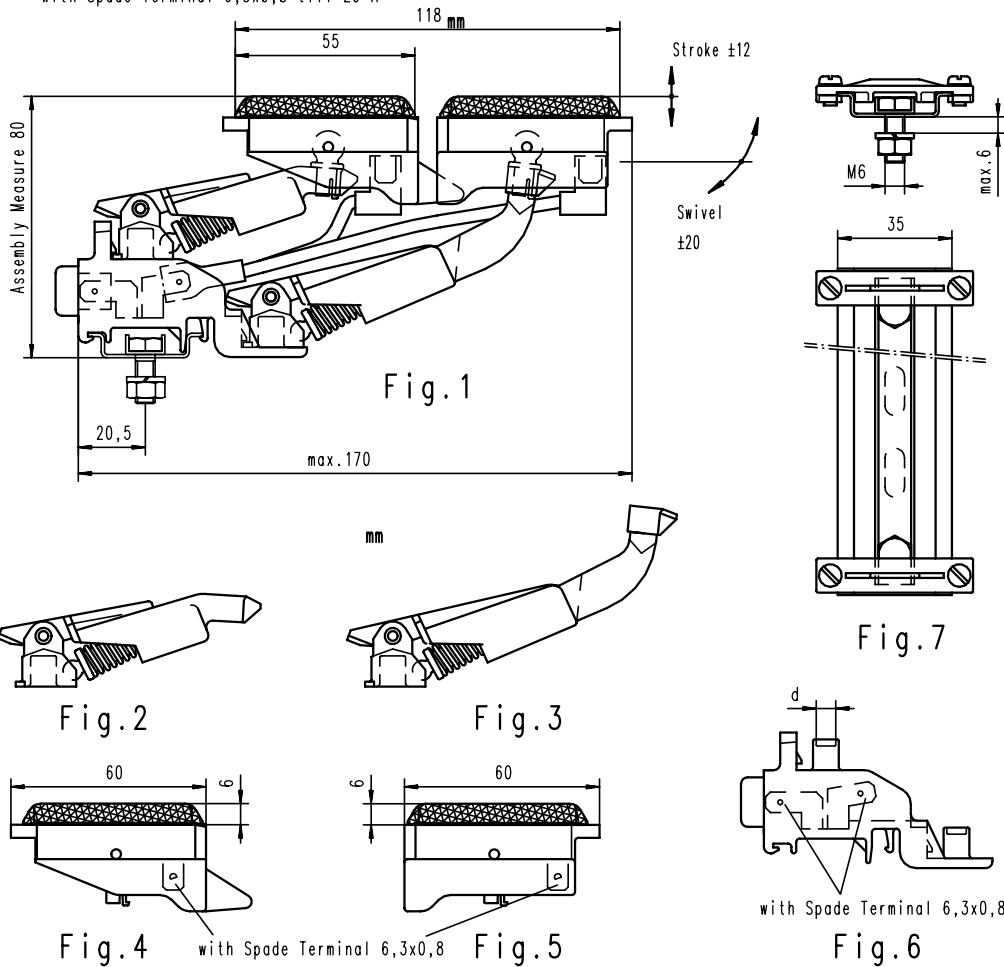
- a) Screw supporting rail to bracket.
- b) Hang up current collector to supporting – clip on 1 and 2 – push them together as a packet. Align supporting rail in such a way that the current collectors are centered or are situated in the centre of the conductor rails. Tighten the end clamps.
- c) Connecting cable
  - To ensure a correct functioning of the current collector, use FABA cables only.
  - Push it – carefully – directly on the collector shoe within the head until the end stop.
  - Guide only one cable at a time through the orifice of the base plates – do not squeeze the cable, it must be freely movable.
  - The cable has to be installed tension and twist-free regarding the current collector head.
  - The bundling of several cables must always be effected behind the base plate.
- d) Current collector head replacement:
  - Press hinge pin – arrow A – slightly together with the finger and pull off the head.
  - When mounting the head, clip in hinge pin.



### Tandem Collector DE AS-20

Spring Pressure approx. 2 x 4 N

with Spade Terminal 6,3x0,8 till 20 A



Order No..	Fig.	Identification					Weight			
241 035 750	1	DEAS-Collector completed with 2 cables	Ground	Spade- Terminal	Black Head	Copper Shoe	0,080			
241 035 751						Yellow Head and Foot	Copper Shoe	0,082		
241 035 752						Grey Head	Silver Shoe	0,078		
241 035 775	2	Front Collector Body	Ground		Foot Yellow		spare	0,012		
241 035 776							only	0,012		
241 035 780	3	Rear Collector Body	Ground		Foot Yellow		spare	0,014		
241 035 781							only	0,014		
241 035 765	4	Front Replacement Head	Ground	Spade- Terminal	Black	Copper Shoe	0,016			
241 035 766						Yellow	Copper Shoe	0,016		
241 035 767						Grey	Silver Shoe	0,014		
241 035 770	5	Rear Replacement Head	Ground	Spade Terminal	Black	Copper Shoe	0,016			
241 035 771						Yellow	Copper Shoe	0,016		
241 035 772						Grey	Silver Shoe	0,014		
251 035 810	6	Base plate w. integrated triple spade terminal	Ground		Orange	Bolt-d = 5	spare	0,018		
251 035 811							Yellow	Bolt-d = 6	only	0,018
241 035 801	7	Support Rail		3-/ 4-poles	Length	L = 100	Center point spacing 15 mm complete with 2 end clamps and 2 attachment screws	0,078		
241 035 802								5-/ 6-poles	L = 125	0,090
241 035 803								7-/ 8-poles	L = 150	0,102
241 035 804								9-/10-poles	L = 175	0,114
241 040 921		Anschlussleitung DE AS 2,5 mm <sup>2</sup>		L = 1 m	Phase	Gerader Steckanschluss 6,3x0,8	0,038			
241 040 922	L = 2 m			Phase	0,076					
241 040 923	L = 3 m			Phase	0,114					
241 040 924	L = 4 m			Phase	0,152					

Order No..	Identification				Weight
241 040 925	Feed Cable DE AS 2,5 mm <sup>2</sup>	L = 1 m	PE	Straight Connection 6,3x0,8	0,033
241 040 926		L = 2 m	PE		0,066
241 040 927		L = 3 m	PE		0,099
241 040 928		L = 4 m	PE		0,132
241 040 931	Feed Cable DE AS 2,5 mm <sup>2</sup>	L = 1 m	Phase	Cornered Connection 6,3x0,8	0,038
241 040 932		L = 2 m	Phase		0,076
241 040 933		L = 3 m	Phase		0,114
241 040 934		L = 4 m	Phase		0,152
241 040 935		L = 1 m	PE	0,033	
241 040 936		L = 2 m	PE	0,066	
241 040 937		L = 3 m	PE	0,099	
241 040 938		L = 4 m	PE	0,132	

### Technical Information

- Suitable for control Signals because of 2 fully independent collector heads.
  - Permissible Ambient Temperature - 30 °C till + 80 °C.
  - Phase and Ground Collector are not interchangeable and have different colors.
  - Female Angled or Female Straight terminal 6,3x0.8 are used for further connection.
  - Further connecting cable must be ordered separately.
  - Foot and Head are self centering in take out position ;enabling easy insertion in rail.
  - Ground Collector is 3 mm higher enabling first in last out safety contact.
  - Suitable for speeds till 400m/min and back and forth operations
    - for contact surface facing down or sideways
    - for bending min 500mm,in all directions
    - for 4mm transfer air gap disalignment using larger transfer caps
    - for use with pick-up guides
- Permissible continuous current 20 A till 40 C Ambient Temperature.  
At higher temperatures reduce as to table.
- At rail center spacing of more than the standard 15 mm
  - Pick up guides will not function
  - In damp environments or outside applications at least 30mm centering of collector rails is necessary, to avoid current creepage.

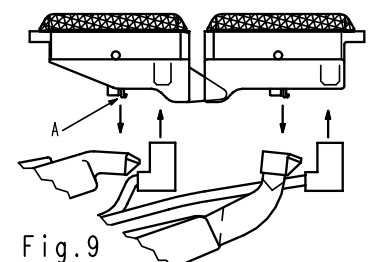
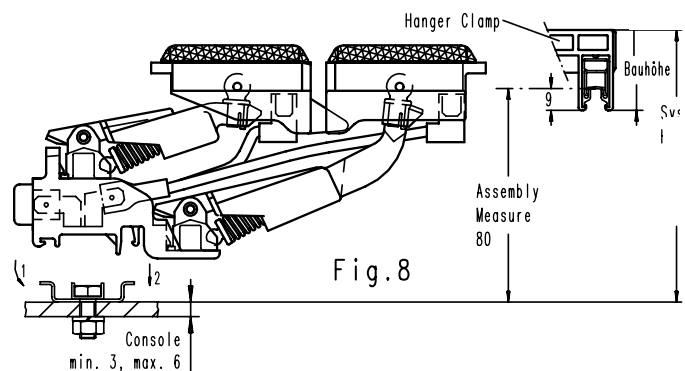
### Planning Instructions

- For the desired free movement of the collectors, pay special attention that the stroke and swivel tolerances are maintained over the whole conductor rail system.
- Install collector assembly as close as possible middle to the carrier drive roller.
- The steel console for connecting the collector support rail must be parallel to the conductor rails to avoid negative function of the collector assembly.

### Installation Instructions

#### Fig ( 8 )

- Secure collector support rail on proposed steel console max 6mm.
- Clip tandem collectors on support rail see movement 1 and 2 on Fig 8.  
Push collectors together centering them to conductor rails  
Tighten end clamps  
If necessary loosen the two nuts below for final centering and slide whole unit up or down to center ; Fasten after completion
- Collector Cable:
  - The Tandem collector is already furnished with 2 cables which are secured to a tripled spade terminal at the base
  - One spade terminal is left for a straight or angled female terminal 6,3x0,8 mm
  - Cables can be chosen from the catalog (or terminals )
- Collector Head Change ( Fig 9 ):
  - Pull off female terminal from collector shoe.
  - With finger push retaining lug ( A ) together and pull off head.
  - To install, push lug through collector arm hole and push terminal on.

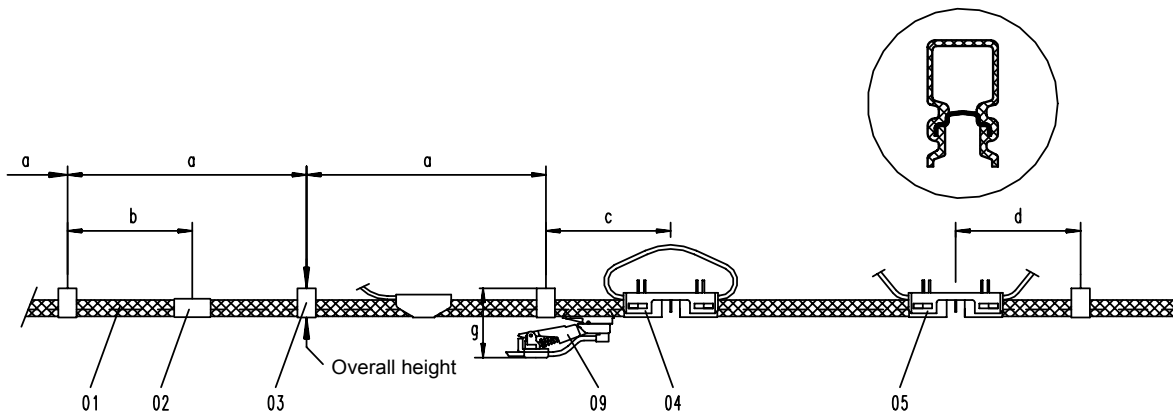






## Conductor Rail FABA 100 System

for mobile equipment



We have extended our insulated FABA 100 Conductor Rail System to include a **low-priced copper rail**.

The FABA 30 Contact Rail is suitable

- Above all as additional control rail for the transmission of information like electronic data;
- But also as an outside rail for the transmission of continuous currents up to 30 Ampere.

In the search for a low-priced design, our Development Department took completely new directions which have led to an absolutely new solution :

The metal rail with the minimal cross-section of 5 mm<sup>2</sup> is manufactured simultaneously with the insulating jacket in one extrusion operation. Both form a unit together.

The FABA 30 conductor rail has the same outside dimensions as the FABA 40 and FABA 100 conductor rails and can be combined with these rails.

It goes without saying that the FABA 30 conductor rail has all of the advantages of our FABA 40 and FABA 100 rails, independent of whether it is used **exclusively in a system or additionally**.

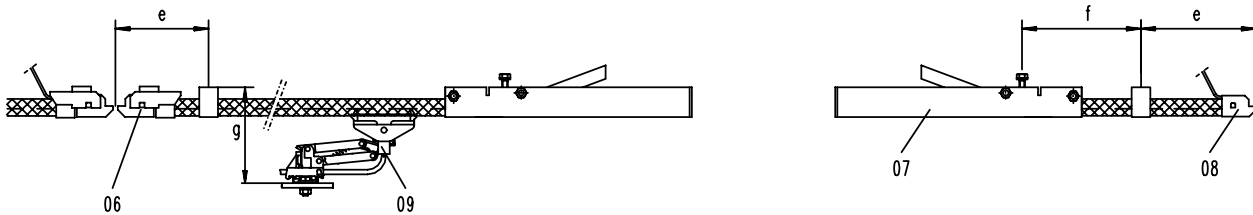
With the FABA 30 conductor rail, you are using a technically high-valued product and thereby an optimum addition to our FABA 100 conductor rail system; in the context of the project planning, costs can be saved in the erection of the system.

*Please contact us if you require our advice or our support especially in the project planning/installation.*

<b>Dimension</b>	a = Hanger spacing in straight lines, max. 600 mm, max. 300 mm in curves; with the following components, maintain the following at least on one side :
	b = To rail connector = min. 100 mm, max. 200 mm
	c = To expansion point = min. 100 mm, max. 200 mm
	d = To electrical separation point = min. 100 mm, max. 200 mm
	e = To mechanical separation point (if single-pole transfer cap) or to end cap = min. 100 mm, max. 200 mm
	f = To cone = max. 500 mm
	g = System height = Top edge of hanger clamp to lower edge of collector mounting : as for FABA 40 / FABA 100.

## FABA – a Product of FAHRLEITUNGSBAU GmbH





### 01 FABA 30 Conductor Rail

As control rail or for continuous currents up to 30 Ampere; 5 m long; sliding surface arrangement facing downwards or to the side optionally; radii from 0.5 m; ambient temperatures from - 30°C to + 55°C (higher temperatures on enquiry); same outside dimensions as FABA 40 / FABA 100, so that combinations with each other are possible without restriction;  
Same conditions with respect to the General IS 100 A List on travel stretch, space, hand area and data transmission.

### 02 FABA 30 Rail Connector

Simple installation without tools by pushing together. Can accept up to 6 mm rail expansion.

### 03 Hanger Clamp

The same models of FABA 40 / FABA 100 are used, so that rail centre spacing minimum and usually is 15 mm; the overall height depends upon local conditions.

### 04 FABA 30 Expansion

Lengthwise changes of the sliding line are compensated for with the butt connector; the expansion bridge for expansions up to 20 mm with electrical bridging is illustrated in the figure; furthermore, expansion rails for expansions of 40 mm and 60 mm are available; a fixed point is to be located between the expansion points.

### 05 FABA 30 Electrical Separation

For example, at repair stretches or to trigger control impulses, with the possibility of line connection on one or both sides; the separation accepts expansions up to 20 mm.

### 06 FABA 30 Mechanical Separation

For example, at switches, lifting stations, sliding platforms, with the possibility of line connection on one side or both sides; shown as multi-pole transition (also available as single-pole transition optionally).

### 07 Pick – Up Guides

For larger sliding rail interruptions for the raising and lowering of the collectors; the same multiple-pole designs of FABA 40 / FABA 100 are used. For systems with pick up guides, use only parallel arm collector.

### 08 FABA 30 End Cap

At the end of the system with the possibility of feeding; used also for ground rail.

### 09 Slider

The same listed designs of FABA 40 / FABA 100 (List IS 100 B) are applicable. For systems with pick up guides, use only parallel arm collector.

### Conductor Rail

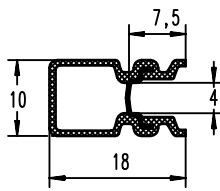


Fig. 1

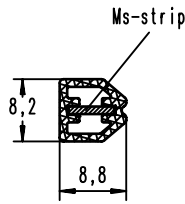


Fig. 2

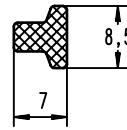


Fig. 3

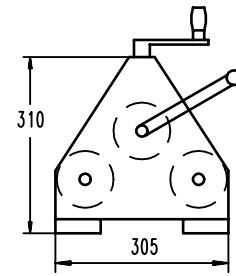


Fig. 4

der No.	Fig.	Description	Length				Weight
200 501 499	1	FABA 30 conductor rail	5 m	Metal rail	Insulating jacket	Orange	0.530
200 502 499			5 m	Copper	Hard PVC	Ground Yellow with green stripes	0.530
241 000 007	2	Bending profile Grey	5 m	PVC	With brass strip	Remains in curved piece	0.460
241 000 006	3	Bending profile Red	5 m	PVC		Can be used repeatedly	0.250
241 045 001	4	Bending machine	( Identical to FABA 40 / 100 )			For manual operation	11.20
518 503 000	with-out	Fine file	( Identical to FABA 40 / 100 )				0.095
518 505 000		Hacksaw	( Identical to FABA 40 / 100 )				0.135
518 505 010		Saw blades				12 pcs; for replacement	0.038

### Technical Information

- Allowable ambient temperatures - 30 °C to + 55 °C.
- Metal rails and insulating jackets are equally long; lengthwise displacements relative to each other are not possible (as if extruded together).
- Metal rail cross-section 5 mm<sup>2</sup>.
- Linear coefficient of expansion  $\alpha = 17 \cdot 10^{-6} [K^{-1}]$ .

	With continuous ambient temperature up to [ °C]				
	35	40	45	50	55
<b>Allowable continuous current [A]</b> at 100 % Duty cycle	30	27	24	21	18
<b>Resistance with alternating current (impedance)</b> [Ohm/km] with direct current	4.42	4.75	5.08	5.39	5.66
	4.22	4.53	4.85	5.14	5.41

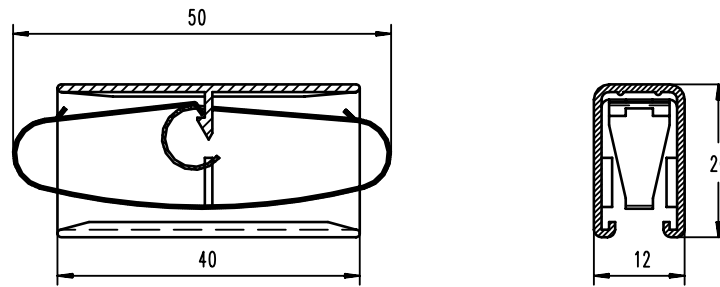
### Planning Information

- In principle, as for FABA 40 / FABA 100.
- Hanger spacing : max. 600 mm in straight lengths; max. 300 mm in curves.
- Conductor rails can be shortened on location.
- Radii are possible in all directions : from 0.5 m "on location".  
Grey bending strips necessary only with continuous radii under 0.75 m or with rail separation in the radius.

### Assembly Instructions

- In principle, as for FABA 40 / FABA 100.
- Hanger spacing: max. 600 mm in straight lengths; max. 300 mm. in curves.
- Shorten: With fine-toothed metal saw, begin sawing from the sliding surface. Deburr cut surfaces – especially the metal sliding surface – carefully with a fine file.
- Curves: Manufacture with bending machine and bending profile; "on location" in general, smallest bending radius 500 mm to all sides.
  - Determine approximate length of curve and mark on the insulating jacket with felt pen. Mark min. 150 mm from beginning of rail (beginning and end cannot be bent, remain straight).
  - When bending over the sliding surface or the rail back, insert grey bending profile. The ends to be connected must be free of grey bending strips 30 mm each.
  - When bending over rail broad side, insert grey bending profile as before and insert red bending profile in the sliding surface slot.
  - Slide rail into the bending machine, until the first curve marking is located centered over one of the lower rollers. Depending on required radius, tighten the upper roller. Guide rail through machine to the second marking. Correction is possible by performing again. For same curve, note the scale setting.
  - If two rail curves must be joined to each other, shorten the rails to be connected by the straight end (approx. 150 mm).

### Rail Connector



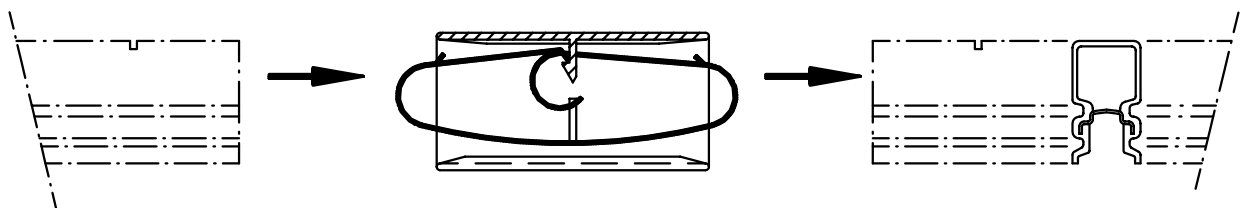
Order No.	Description		Weight
241 002 005	FABA 30 butt connector	Single-pole; completely pre-assembled; spring bronze; Housing, red plastic	0.005

### Technical Information

- Allowable continuous current 30 Ampere (at 100 % Duty cycle).
- Allowable ambient temperatures - 30°C to + 55°C.
- > The two-piece rail connector is delivered preassembled; the parts are connected together and cannot be lost.

### Planning Information

- Distance to the next closest hanger clamp: min. 100 mm; max. 200 mm.
- Use also for conductor rail joint in curve.
- \* The rail connector cannot be reused / reinstalled.
- A gap of 1 mm remains between each rail joint.



- The rail connector can accept up to 6 mm expansion.

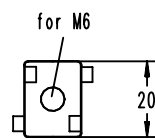
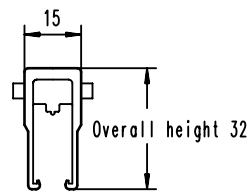
### Assembly Instructions

- Put rail connector on the end of the sliding rail already installed – it does not matter which way around.
- Pay attention to ensure that the housing grips around the insulating jacket.
- Clip next conductor rail into hanger clamps already installed.
- Pull conductor rail to the rail connector and push together till clicked tight.
- Adjust expansion gap – max. 6 mm – in accordance with the lengthwise changes to be expected.
- Check: Are both insulating jackets clamped by both rims of the housing?

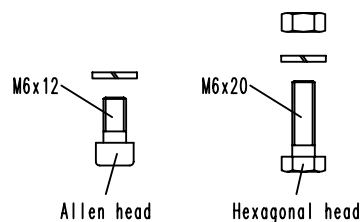
### Hanger Clamp

For suspension and/or mounting of the FABA 30 conductor rail, the **same FABA 40 / FABA 100 hanger clamps** are used.

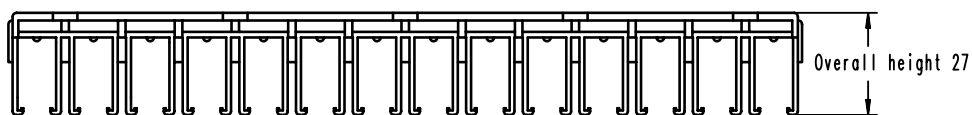
We refer to  
 List IS 100 B = Standard hanger clamps and  
 List IS 100 K = Additional hanger clamps.



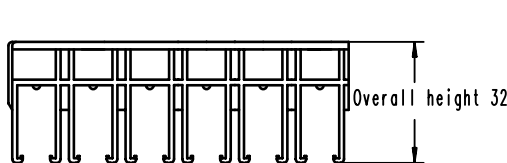
Single-pole, can be placed in row



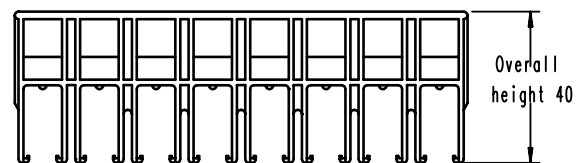
Screw fittings



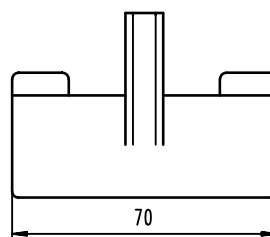
4- 14-pole



2- 12-pole



4- 8-pole



Rail removal tool from hanger (as assembly aid)

### Power feeds

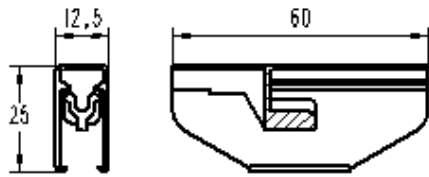


Fig. 1

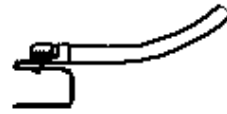


Fig. 2



Fig. 3

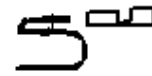


Fig. 3a

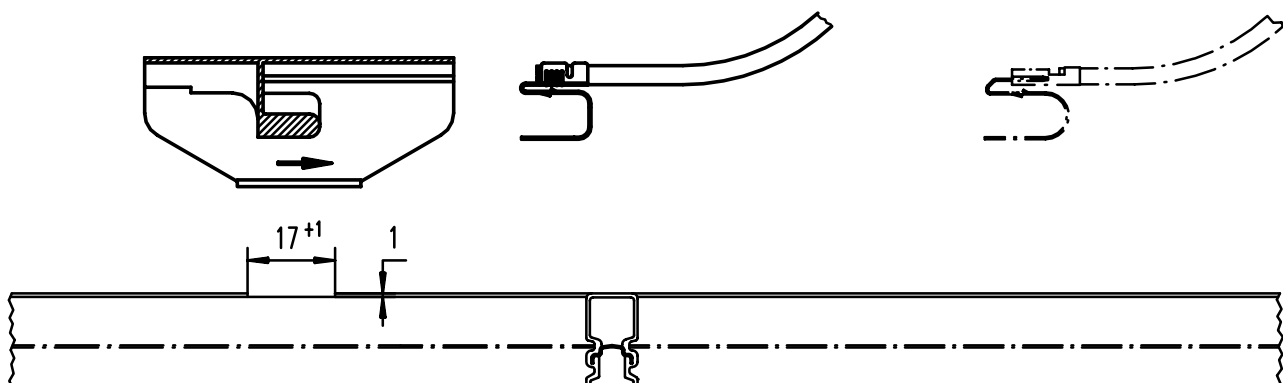
Order-No.	Fig.	Identification			Weight
241 015 045	1 + 3	Power feed	Without connecting cable	Housing and plug in bag	0.007
241 015 046	1 + 3a	<b>FABA 30</b>	Without connecting cable	Housing, pluck and flat plug sleeve 1mm <sup>2</sup> + 2,5mm <sup>2</sup> in bag	0.010
241 015 042	1 + 2	Power feed	With connecting cable 2.5 mm <sup>2</sup>	Housing and connecting cable 1 m long	0.050
241 015 043		<b>FABA 30</b> PE	With connecting cable 2.5 mm <sup>2</sup>	in bag	0.043
241 015 044		Data	With connecting cable 2.5 mm <sup>2</sup>	(other lengths on request)	0.043
241 026 055	1	Housing	Plastic-red		0,005
241 026 024	3	Plug	Bronze; for cross sections 1.5 mm <sup>2</sup> and 2.5 mm <sup>2</sup>	<b>Only If re- placed</b>	0.002
241 026 041	3a	Plug	Bronze; with plug connection 6.3x0,8		0.002
241 040 377	2	Connecting	2.5 mm <sup>2</sup> Outer-Ø 4.5 1 kV black	Single-core, halogenfree, flexible;	0.045
241 040 378		Cable	2.5 mm <sup>2</sup> Outer-Ø 3.9 PE green-yellow	One-side with plug;	0.038
241 040 379	1 m long	Data	1.5 mm <sup>2</sup> Outer-Ø 5.1 grey	(other lengths on request)	0.038

### Technical information

- Permissible continuous current depends on the feeder line (and of the ambient temperature) max. 30 A
- Permissible ambient temperatures: – 30 °C up to + 55 °C

### Planning instructions

- Suitable for assembly heights larger than 27 mm, for all conductor rails including PE
- Also suitable for bends larger than R = 1000 mm
- Use enclosed receptacles only



### Installation instructions

- Treat conductor rail – as dimensioned (remove chips)
- Put plug with connecting cable on the journal of the housing
- Attach housing to conductor rail and displace it until it engages

### Expansion – General information

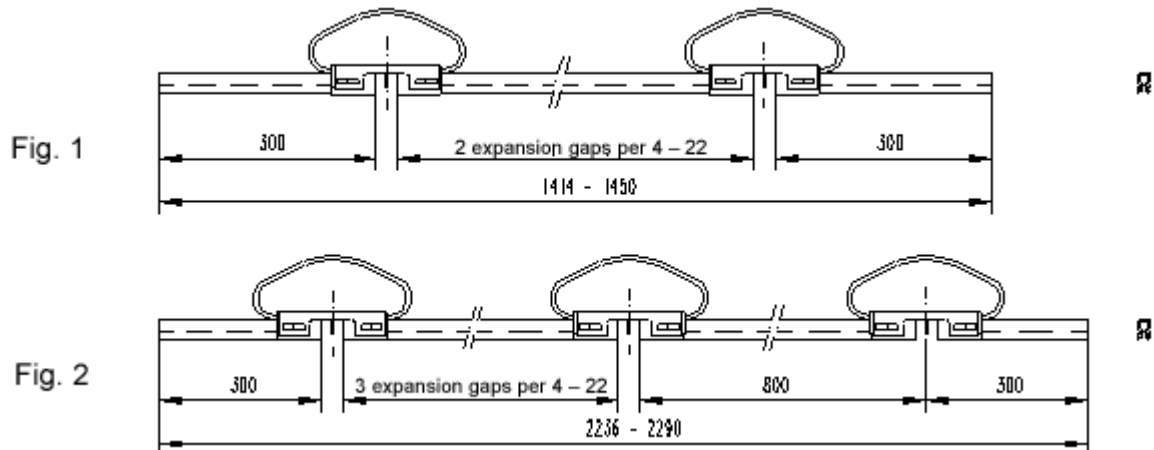
- a) In principle, the same information and handling as for FABA 40 / FABA 100.
- b) Through fluctuations in the ambient temperatures or the heat generated, the length of the conductor rail changes. Fixed points arrest the conductor rail at certain points, thus controlling any linear displacement.
- c) **Linear installations up to a length of 60 m** only require a centered fixed point. Each rail splice can compensate for a change of length of up to 6 mm.
- d) **All other installations** – i.e. straight rail sections longer than 60 m – will require components compensating for the change of length:
  - **Expansion rail** for changes of length of up to 36 mm or 54 mm
  - **Electrical separation**; compensates for linear expansions of the conductor rail up to 18 mm. It can also be exclusively used as an expansion bridge at the rail splice, in this case, however, a cable for electric bridging will be required.
- e) **Fixed points have always to be installed**; these are components which arrest the conductor rail in combination with a hanger clamp. Usually, they are to be installed in the centre between to expansion points, for radii preceding or following the bend, for counter directed bends, the fixed point is to be installed in the centre of the bend.

Equal fixed point as for FABA 40 / FABA 100 (list IS 100 B).

**Apart from a good planning of the conductor rail installation, a correct and orderly installation is indispensable for the dependable operation and this not only for standard installations but also for extensively branched circuits - or for high travelling speeds, extreme fluctuations of temperature etc.**

*Because of our substantial experiences we are happy to be of assistance to you in the planning and suggest to have the installation carried out by our trained personnel - not in the least to guarantee the warranty on the proper function of our components or our FABA 100 system.*

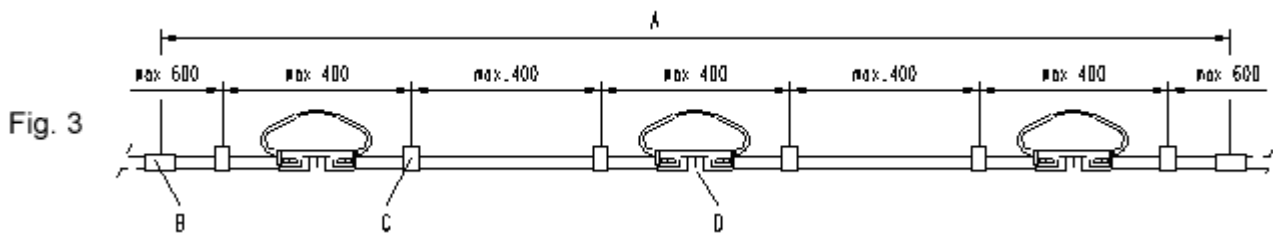
### Expansion rail for building expansion



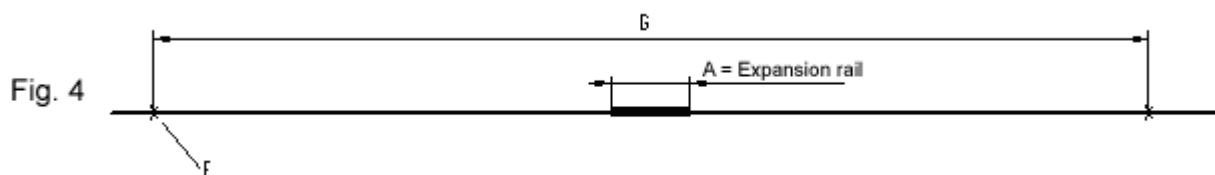
Order No.	Fig.	Identification	Total expansion	Rail insulation		Weight
211 010 172 211 010 182	1	36 mm Expansion rail FABA 30	2 x 18 = 36 mm	orange yellow w. green stripe PE	One-pole;  for assembly heights + 27 mm;	0.220 0.220
211 010 173 211 010 183	2	54 mm	3 x 18 = 54 mm	orange yellow w. green stripe PE	shipped ready to be installed	0.330 0.330

#### Technical information

- Suitable for control operations and for continuous currents up to 30 A, Reduction by increased ambient temperatures as for conductor rail FABA 30
- Permissible ambient temperatures: - 30 °C up to + 55 °C
- Each expansion gap is bridged by a highly flexible line of 2.5 mm<sup>2</sup>
- Metal rail and insulating sleeve are of equal length



- A = Length of the expansion rail
- B = Splice connector (does not belong to this scope of delivery)
- C = Hanger clamp (does not belong to this scope of delivery)
- D = Expansion gap: 4 - 22 mm each, measured between the caps
- F = Fixed point or fixing point clip (does not belong to this scope of delivery)
- G = Expansion



### Expansion rail – Continuation –

#### Planning instructions

- a) In princ, the same as for FABA 40/FABA 100.
- b) Mainly used for building and running rail expansion joints
- c) Suitable for expansion heights + 27 mm.
- d) For all expansion rails – also PE.
- e) For a change of length of the conductor rail of up to 36 mm or 54 mm.
- f) Plan additional hanger clamps (see fig. 3).
- g) Changes of length up to 18 mm are compensated for by expansion bridge or by electrical separation (see next page).
- h) Max. length of the expansion G  
or distance of the fixed points F:  
\* If an extension rail is only used to compensate for the building or running rail expansion joint, a fixed point will be installed directly beside the expansion rail.

		Max. permissible length of the expansion G [m]					
Expansion rail	Duty	Difference in temperature [K]					
FABA 30	Duty cycle	10	20	30	40	50	60
Expansion total 36 mm	100 %	60	50	42	36	31	28
	60 %	60	60	50	42	36	31
	40 %	x	60	60	50	42	36
Expansion total 54 mm	PE or Control / Data	x	x	60	60	50	42
	100 %	xx	60	60	54	46	42
	60 %	xx	xx	60	60	54	46
Expansion total 54 mm	40 %	xx	xx	xx	60	60	54
	PE or Control / Data-	x	x	xx	xx	60	60

Note: The expansion G is always max. 60 m.

x = For normal linear compensation, plan expansion bridge.  
xx = For normal linear compensation, it is advisable to plan expansion rail - of 36 mm.

**Example:** Possible ambient temperature: max. + 35 °C, min. - 5 °C; thus, the difference in temperature will be = 40 K [Kelvin];  
acc. to the table, the expansion G will be = max. 60 m when using the expansion rail with an expansion of 36 mm and transfer of control commands or electronic data.

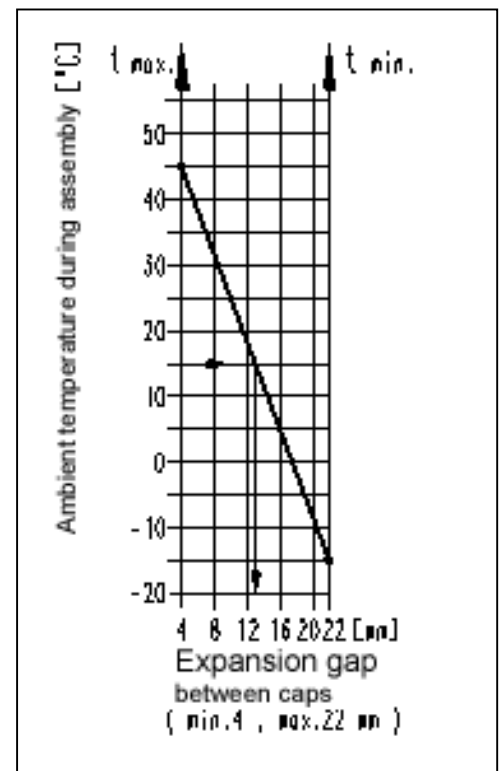
#### Installation instructions

- a) In principle, the same as for FABA 40 / FABA 100.
- b) Hanger clamps: Installation right and left of the expansion gap; distance: max. 400 mm, to further: max. 800 mm as usual (see fig. 3).
- c) To be used for building and running rail expansions:
  - Install the expansion rail centered to the expansion joint
  - Install a fixed point directly left and right of the expansion rail
- d) Adjust expansion gap (distance between the caps):
  - Expansion rail Acc. to fig. 1 = max. 44 mm (2 x 22 mm);
  - Expansion rail Acc. to fig. 2 = max. 66 mm (3 x 22 mm)
  - For use acc. to c): Expansion gap should correspond to building or running rail expansion joint
  - Expansion gap according to diagram

**Example:** Possible ambient temperatures: max. + 45 °C, min. - 15 °C;  
Mark points in diagram and connect them by a line;  
Temperature during installation = + 15 °C;  
Expansion gap to be adjusted: approx. 13 mm.

**Note:** For expansion rail 36 mm (fig. 1) = 2 x 22 mm, total: 44 mm;  
For expansion rail 54 mm (fig. 2) = 3 x 22 mm, total: 66 mm.

**Important:** Do not alter the expansion gap during the subsequent installation!





### Electrical separation

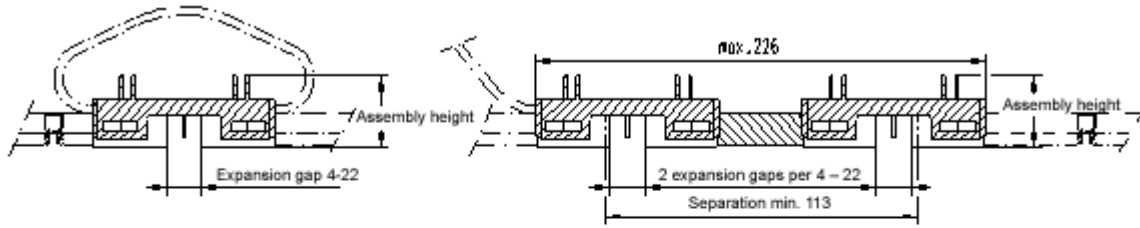


Fig. 1

Fig. 2

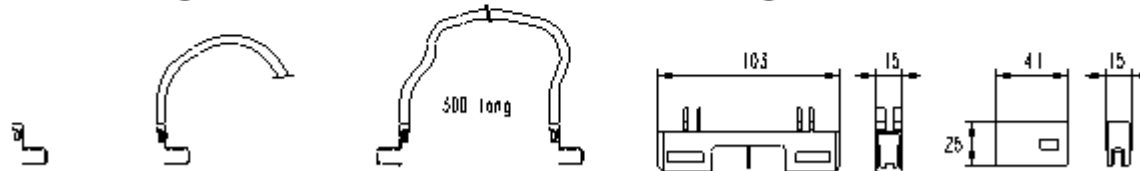


Fig. 3

Fig. 4

Fig. 5

Fig. 6

Fig. 7

Ass. height 27	Order No.		Fig.	Identification	Packed units in bag; consisting of:			Weight		
	Ass. height 32	Ass. height 40			Fig. 3	Fig. 4	Fig. 5	AH 27	AH 32	AH 40
	241 025 071	241 025 072	1	Electrical separation <b>FABA 30</b>	1 piece fig. 6 and 2 pieces fig. 7					
	241 025 074	241 025 075			2 pieces	without cable	----	0.018	0.019	0.019
	241 025 083	241 025 084			1 piece	1 piece 1.5 mm <sup>2</sup>	----	0.048	0.049	0.049
	241 025 077	241 025 078			1 piece	1 piece 2.5 mm <sup>2</sup>	----	0.061	0.062	0.062
	241 025 086	241 025 087			----	2 pieces 1.5 mm <sup>2</sup>	----	0.078	0.079	0.079
	241 025 080	241 025 081			----	2 pieces 2.5 mm <sup>2</sup>	----	0.104	0.105	0.105
		241 025 082			----		1 Stück	0.032	0.033	0.033
	241 025 101	241 025 102	2	Galvanic separation <b>FABA 30</b>	2 pieces fig. 6 and 2 pieces fig. 7 and 1 insulating piece (not shown)					
	241 025 107	241 025 108			2 pieces	without cable	----	0.040	0.042	0.042
	241 025 110	241 025 111			1 piece	1 piece 1.5 mm <sup>2</sup>	----	0.070	0.072	0.072
	241 025 104	241 025 105			1 piece	1 piece 2.5 mm <sup>2</sup>	----	0.083	0.085	0.085
	241 025 113	241 025 114			----	2 pieces 1.5 mm <sup>2</sup>	----	0.100	0.102	0.102
		241 025 115			----	2 pieces 2.5 mm <sup>2</sup>	----	0.126	0.128	0.128

Order No.	Fig.	Identification	<i>Only if replaced</i>		Weight
241 026 023	3	Plug	Bronze; without cable		0.002
241 040 372		1 m long 2.5 mm <sup>2</sup>	Outer-Ø 4.5 ;	1 kV black; single-core; halogenfree, flexible; one side with plug; (other lengths on request)	0.045
241 040 375	5	Bridging 2.5 mm <sup>2</sup>	Outer-Ø 4.5 ;	1 kV black; single-core; halogenfree, flexible; two sides with plug; 300 mm long	0.018
241 006 177			Assembly height 27		0.006
241 006 176	6	Bracket	Assembly height 32	one-pole; plastic-red	0.007
241 006 175			Assembly height 40		0.007
241 017 125	7	Cap		one-pole; plastic-red	0.004

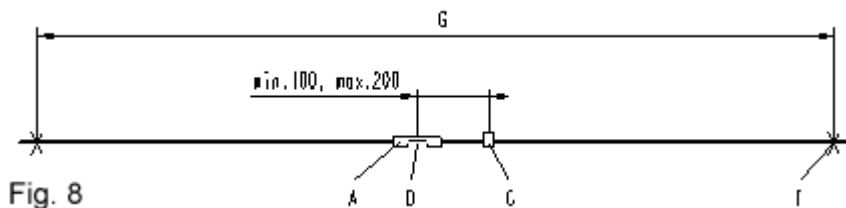


Fig. 8

- A = Electrical or galvanic separation
- C = Hanger clamp
- D = Expansion gap
- = 4-22 or 2 x 4-22
- F = Fixed point
- G = Expansion

### Electrical Separation – Continuation –

### Technical information

- In principle, similar to FABA 40 / FABA 100.
- Permissible ambient temperatures: - 30 °C bis + 55 °C.
- The electrical separation with bridging, fig. 1, is usually used for the linear compensation of the conductor rail (in special cases, it is also used as a bridging to the adjacent conductor rail), transmission of the bridging line: up to 30 A at an ambient temperature 35 °C, for higher temperatures: Reduction acc. to VDE standards.
- Regarding the separation: The conductor rail will be separated e. g. for control tasks.
  - Design of fig. 1: During the travel, the conductor rail ends are electrically bridged by **one** collector shoe, the connection is possible either on one or on both sides.
  - Design of fig. 2: The centre section consists of insulating material, the distance of the metal conductor rails is min. 113 mm to avoid a bridging by a current collector
  - The separations also compensate for the change of length of the conductor rail

### Planning instructions

- If the design incl. bridging acc. to fig. 1 is not used as a separation, but exclusively as an expansion compensation, this will be also applicable for PE
- The electrical separation will usually not be used for PE-rails.
- At least on one side for galvanic separation on both sides from min. 100 mm up to max. 200 mm (see fig. 8) one additional hanger clamp is to be planned, if the bracket is not mounted on the web, consider the assembly height.
- Installation is practically possible at any place of the system

		Permissible max. length of the expansion G [m]					
Type/Design	Duty Duty Cycle (DC)	Difference in temperature [K]					
		10	20	30	40	50	60
acc. to fig. 1	100 %	31	25	21	18	15	14
	60 %	42	31	25	21	18	15
	40 %	60	42	31	25	21	18
	PE or Control / Data-	60	60	42	31	25	21
acc. to fig. 2		60	60	60	60	50	42

Note: The expansion will always be max. 60 m.

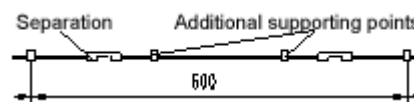
Also later, always between 2 fixed points, if the expansion is to be compensated for in linear sections only, not for bends.

- When using the galvanic separation acc. to fig. 2 2 current collectors will usually be required.
- The possible max. length of the expansion G depends on the difference in the occurring ambient temperatures. In case of control tasks or data transfer, the heat generated will not be taken into account.

**Example:** Possible ambient temperatures: max. + 45 °C, min. + 5 °C; thus, the difference in temp. is = 40 K [Kelvin] ; acc. to table, the type acc. to fig. 1 for 60 % duty cycle:  
Expansion G = max. 21 m.

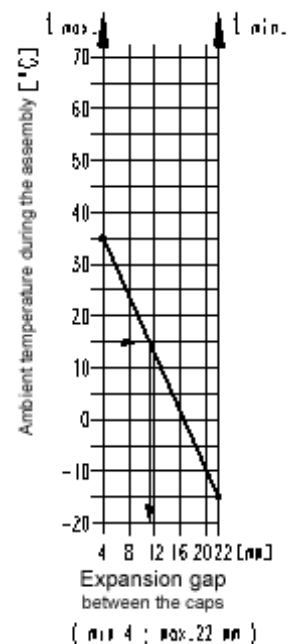
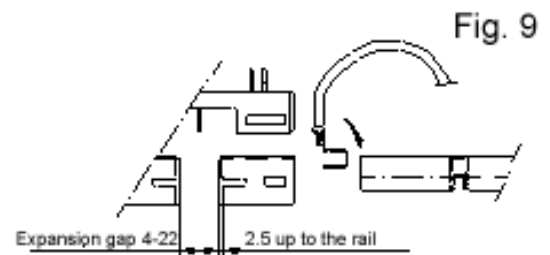
### Installation instructions

- In principle, similar to FABA 40 / FABA 100.
- Insert plug – with or without cable- to the end of the rail until the end stop, bend the end of the plug – see arrow in fig. 9;  
Push on cap until it engages, both legs have to embrace the rail.
- Insert plug and cap into the other end of the rail in the same way..
- Clip on the bracket.
- Does the bracket not lie directly on the conductor/running rails, install a hanger clamp at least on one side, in case of galvanic separation on both sides, at a distance of min. 100 mm, max. 200 mm (fig. 8).  
Separations, produced by short rail sections, have to be suspended by 2 hanger clamps. These hanger clamps may also be installed by attachable clips secured against displacement.
- Install the cables in such a way that the changes of length of the conductor rails are not hindered.
- Adjust expansion gap (distance between the caps) acc. to diagram:  
Component ac. to = max. 22 mm;  
fig. 1 = max. 44 mm (2 x 22 mm).  
Component ac. to fig. 2



**Example:** Possible ambient temperatures: + 35 °C, min. – 15 °C;  
Mark points in the diagram and connect them by a line; temperature during the assembly = + 15°C;  
Expansion gap to be adjusted approx. 11 mm.

**Important:** Do not alter the expansion gap during the subsequent installation procedure!



### Mechanical separation

#### GENERAL

The conductor rail has sometimes to be separated mechanically – and at these locations of course also electrically, e.g.

- At switches, shunting stages and lifting stations; caps have to be installed at the transitions
- For crosswise traffic, a larger length of the rail section will be separated; for the back and forth movement of the current collectors, pick up guides will be used.

On the following pages, the components for the FABA 30 conductor rail are listed up and described, they are similar to, sometimes even identical to FABA 40 / FABA 100.

We therefore refer also to the information of list IS 100 B Standard-Components (Transfer caps, one-pole) and to list IS 100 U Separations.

#### Content of the following pages

- Transition at switches, etc., with one-pole transfer caps **FABA 30**, for displacements acc. to fig. 1 – 3. Combinations with adjacent conductor **FABA 40** or **FABA 100** are of course possible and will cause no problems.
- Multiple-pole transition at switches, etc., with straight caps for **FABA 30** und in combination with **FABA 40 / FABA 100**; for displacements acc. to fig. 4 - 6.
- Multiple-pole transition at switches, etc., with diagonal-cut caps for conductor rails **FABA 30** and in combination with **FABA 40 / FABA 100**; for displacements acc. to fig. 7 and 8.
- Separation for larger rail sections, multiple-pole, acc. to fig. 9; with pick up guide for conductor rails **FABA 30** and in combination with conductor rails **FABA 40 / FABA 100**.

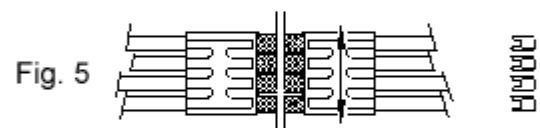
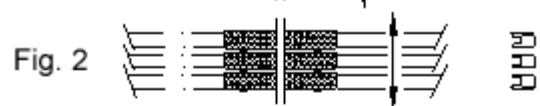
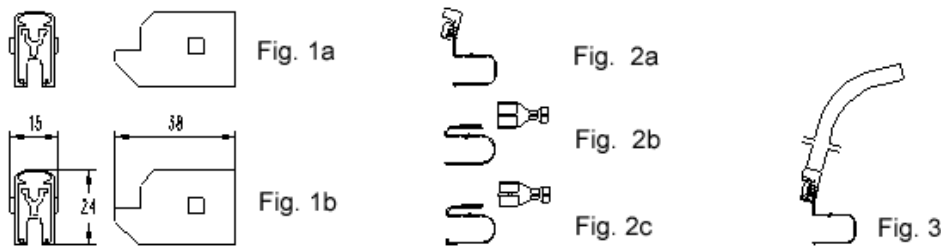


Fig. 9



### Mechanical separation – with one-pole transfer caps

Permissible height/lateral displacement:  $\pm 2$  mm



Order No.	Fig.	Identification			Weight
241 017 160	1a + 2a	Transfer cap	without connecting cable	Cap and plug in bag	0.006
241 017 167	1a + 2b		without connecting cable	Cap, plug, push-on sleeve in bag	0.008
241 017 168	1b + 2c		without conn. cable, adjustable	Cap, plug, push-on sleeve in bag	0.010
241 017 162	1a + 3	<b>FABA 30</b>	with connecting cable, 2.5 mm <sup>2</sup>	Cap and connecting cable 1 m long in bag (other lengths on request)	0.049
241 017 163			with connecting cable, 2.5 mm <sup>2</sup>		0.042
241 017 164			with connecting cable, 1.5 mm <sup>2</sup>		0.042
			<b>PE</b>		
			<b>Data</b>		
			<b>a</b>		
241 017 005	1a	Transfer cap	Plastic-red		0.004
241 017 167	1b		Plastic-red		0.004
241 026 023	2a	Plug	Bronze; for cross sections of 1.5 mm <sup>2</sup> and 2.5 mm <sup>2</sup>	<b>Only if replaced</b>	0.002
241 026 040	2b		Bronze; with plug connection 6.3 x 0.8		0.003
241 026 042	2c		Bronze; with plug connection 6.3 x 0.8		0.004
241 040 372	3	Connecting cable	2.5 mm <sup>2</sup> outer-Ø 4.5 1 kV black	One-pole; halogenfree, flexible; (other lengths on request)	0.045
241 040 373	1 m long		2.5 mm <sup>2</sup> outer-Ø 3.9 <b>PE</b> green-yellow		0.038
241 040 374	Data		1.5 mm <sup>2</sup> outer-Ø 5.1 grey		0.038

### Technical information

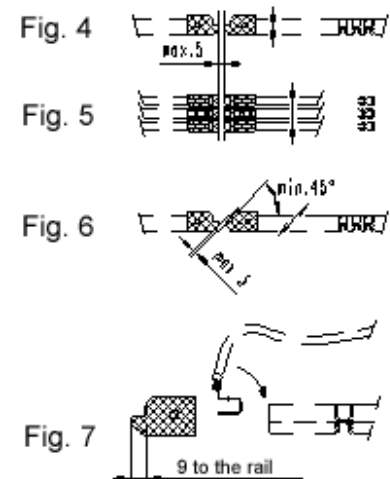
- Use: For separations on switches, etc., also as end cap at the end of the conductor rail – also for PE; Conductor surface facing either down or sideways; for ambient temperatures:  $-30$  °C up to  $+55$  °C ; for conductor rail centre distances from 15 mm on; for travelling speeds up to 300 m/min.; in bends, if radius is at least 750 mm
- Design for data transfer: The connecting cable is PVC-insulated with standard shielding, on request, we also deliver this type with HF-shielding (coaxial cable)
- The permissible height and/or lateral displacement of two opposite caps to one another is **max.  $\pm 2$  mm**

### Planning instructions

- A prerequisite for a correctly functioning transition is a faultlessly operating switch mechanism, even under load by a charged vehicle, for example.
- One current collector per conductor rail is sufficient:** the collector shoe bridges both ends of the metal rails at the transition.
- The PE-conductor rail can be positioned at any place of the system.
- For switch displacement direction acc. to fig. 4 + 5 : **perm. air gap = max. 5 mm**,  
For switch displacement direction acc. to fig. 6 : **perm. air gap = max. 3 mm**.
- Hanger clamps are to be installed behind the caps:  
Distance between them: min. 100 mm, max. 200 mm
- The caps must not wander into the transition range, therefore, install fixing point clips as close as possible.
- Combinations with adjacent conductor rails FABA 40 / FABA 100** may be realised at will: see transfer caps in list IS 100 U, page 3

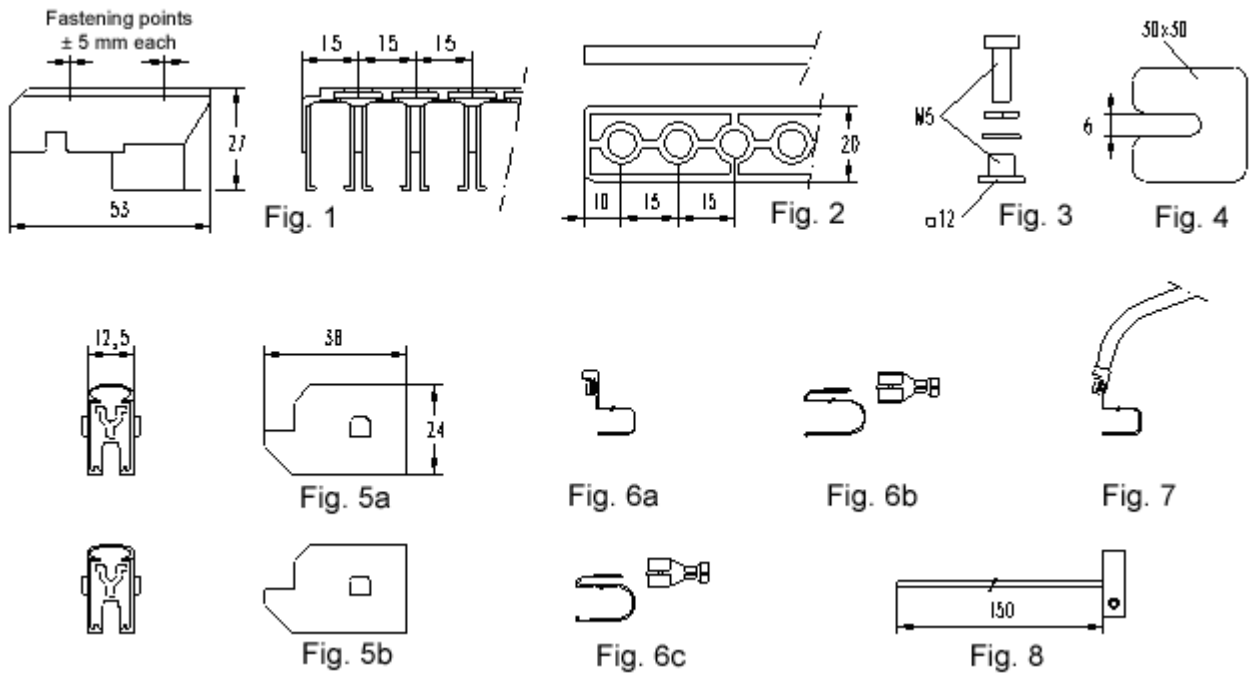
### Installation instructions

- Insert plug – with or without cable – into the conductor rail end until end stop
- Bend plug end – see arrow in fig. 7
- Open cap completely – both legs have to embrace the rail
- Check of all transitions is necessary also during the displacement



### Mechanical separation multiple-pole, with straight caps

Permissible height/lateral displacement  $\pm 2$  mm



Note: Transitions are not complete, the additionally required caps FABA 30 acc. to the table below and for FABA 100 for separation IS 100 U, page 3.

Assembly height 27	Order No.		poles	Identification	Single units in bags ; consisting of:	Weight			
	Assembly height 32	Assembly height 40				BH 27	BH 32	BH 40	
241 006 250	241 006 260	241 006 270	4-	FABA 30/100	Fig. 1	Bracket plastic-orange = 1 piece	0.038	0.046	0.050
241 006 251	241 006 261	241 006 271	5-		Fig. 2	Compensation plate - orange	0.042	0.051	0.057
241 006 252	241 006 262	241 006 272	6-		AH 27 = without ;	0.046	0.056	0.064	
241 006 253	241 006 263	241 006 273	7-		AH 32 = 1 piece 5 thick ;	0.050	0.061	0.071	
241 006 254	241 006 264	241 006 274	8-		Fig. 3	Screw with nut, washer,	0.054	0.066	0.078
241 006 255	241 006 265	241 006 275	9-		lock washer up to 9-pol. = 2 pieces,	0.058	0.071	0.085	
241 006 280	241 006 290	241 006 300	10-		from 10-pol. = 3 pieces	0.072	0.086	0.102	
241 006 281	241 006 291	241 006 301	11-		AH 27 = M5 x 10, AH 32 = M5 x 14,	0.076	0.091	0.109	
241 006 282	241 006 292	241 006 302	12-		AH 40 = M5 x 22	0.080	0.096	0.116	
241 006 283	241 006 293	241 006 303	13-		Fig. 4	Distance plate plastic-orange	0.084	0.101	0.123
241 006 284	241 006 294	241 006 304	14-		1 piece each, 1 mm and 2 mm thick	0.088	0.106	0.130	

Order No.	Fig.	Identification			Weight
241 017 160	5a + 6a	Cap FABA 30	w. crimping plug		0.006
241 017 167	5a + 6b		w. plug connection	Cap plastic-red, plug 6.3 x 0.8 + socket in bag	
241 017 168	5b + 6c		w. plug connection	Cap plastic-red, plug 6.3 x 0.8 + socket in bag	
241 017 162	5a	with cable	Cable	2.5 mm <sup>2</sup> Außen-Ø 4.5 1 kV black	One-pole, halogenfree, flexible; one-side with plug
241 017 163	and			2.5 mm <sup>2</sup> Outer-Ø 3.9 PE green/yellow	
241 017 164	7	1 m long	1.5 mm <sup>2</sup>	Outer-Ø 5.1 Data grey	(other lengths on request)
241 046 030	without Fig.	Drilling jig		for even no. of poles	for electric monorails
241 046 080		Drilling jig		für odd no. of poles	180 x 60
241 024 052	4	Distance plate		15 pieces each, 1 mm and 2 mm thick ; plastic-orange ; in bag	
518 505 062	8	Screw driver SW 3		for hexagon socket screw M5	

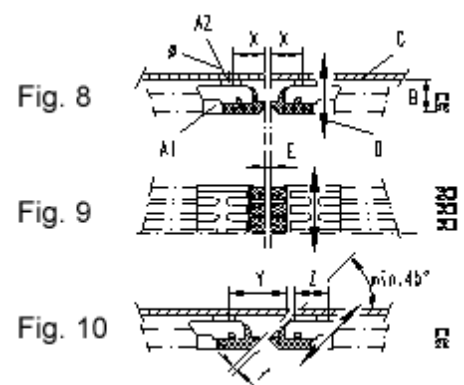
### Mechanical separation multiple-pole, with straight caps – Continuation - Permissible height/lateral displacement: $\pm 2$ mm

#### Technical Information

- Use for separations on switches, etc.;  
conductor surface facing either down or sideways;  
multiple-pole – conductor rail centre distance: 15 mm;  
for ambient temperatures of  $-30$  °C up to  $+55$  °C ;  
for travelling speeds up to 300 m/min.;  
in bends, when radius is at least 750 mm
- Design for data transfer the connecting cable is PVC-insulated with standard shielding, on request, we also deliver this type with HF-shielding (coaxial cable).
- Permissible height and/or lateral displacement of two opposite caps to one another: **max.  $\pm 2$  mm**

#### Planning instructions

- Prerequisite: for a correctly functioning transition is a faultlessly operating mechanical (switch) system even under load e.g. by a charged monorail vehicle
- **One current collector is sufficient per conductor rail:** the collector shoe bridges both ends of the metal rails at the transition.
- The PE-conductor rail may be positioned at any place of the system.
- For switch displacement acc. to fig. 8 + 9 : **Perm. air gap E = max. 5 mm,**
- For switch displacement acc. to fig. 10 : **Perm. air gap F = max. 3 mm.**
- These transitions arrest the conductor rail in the lengthwise direction, thus, these are „fixed points“ with the advantage of maintaining the correctly adjusted transition air gap.
- Conductor rail-combinations of **FABA 30 with FABA 100** can be realised at will, please combine:  
**Transition** consisting of bracket, compensation plate, screws and distance plate (consider the assembly height and the no. of poles), see IS 100 C, page 14
- **Caps** for conductor rails FABA 30 see list IS 100 C, page 14  
for conductor rails FABA 100 see list IS 100 U, page 3  
with or without connecting cable
- The distance plates of fig. 4 ensure the correct transition from cap to cap, if necessary.



#### Installation instructions

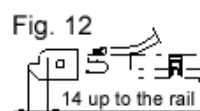
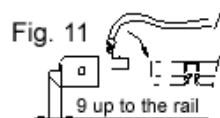
- Drill conductor rail or traversing rail „C“ (use drilling jig, if nec.), up to 9-poles per transition = 2 holes, from 10 poles = 3 holes, for sizes see fig. 8 + 9
- Insert square nuts into the slits of the bracket
- Attach distance parts for assembly heights 32 and 40
- **Loosely** screw down bracket – without caps
- Prepare all transitions in the same way
- Shorten conductor rails – and also all bends – to the exact length, de-burr them thoroughly, also the inner surfaces
- For FABA 40 / 100 see separation IS 100 U, page 3
- For FABA 30: mount cap of fig. 5a to fig. 11:  
Insert plug of fig. 6a or 6b or cable with plug of fig. 7 into the rail and bend it into the direction of the arrow.  
Push cap on the conductor rail
- For FABA 30: mount cap of fig. 5b to fig. 12:  
Insert plug of fig. 6c – with or without connecting cable - until the end of the cap.  
Push them both together on the conductor rail.  
Press cap until it engages
- All caps must always embrace both sides of the conductor rail
- Clip the conductor rails – with the caps mounted – into the brackets, both sides of the conductor rail have to be embraced.
- Align **caps exactly** to the transition air gap: In particular, the caps of fig. 12 can be adjusted by 3 mm.
- **Screw down tightly the bracket** to the running rail/traversing rail
- Check of all transitions is necessary also during the displacement.
- In case of uneven heights from cap to cap, insert, if necessary, distance plates acc. to fig. 4 at the screws to the running rail.

A <sub>1</sub>	=	Bracket
A <sub>2</sub>	=	Compens. plate for assembly height 27 = without for assembly height 32 = 5 thick for assembly height 40 = 13 thick
B	=	Assembly height 27 or 32 or 40
C	=	Monorail-running rail or other traversing rail
D	=	Direction of displacement
E	=	Fig. 8 and 9 transition-air gap: max. 5 mm between the caps
F	=	Fig. 10 transition-air gap: max. 3 mm between the caps

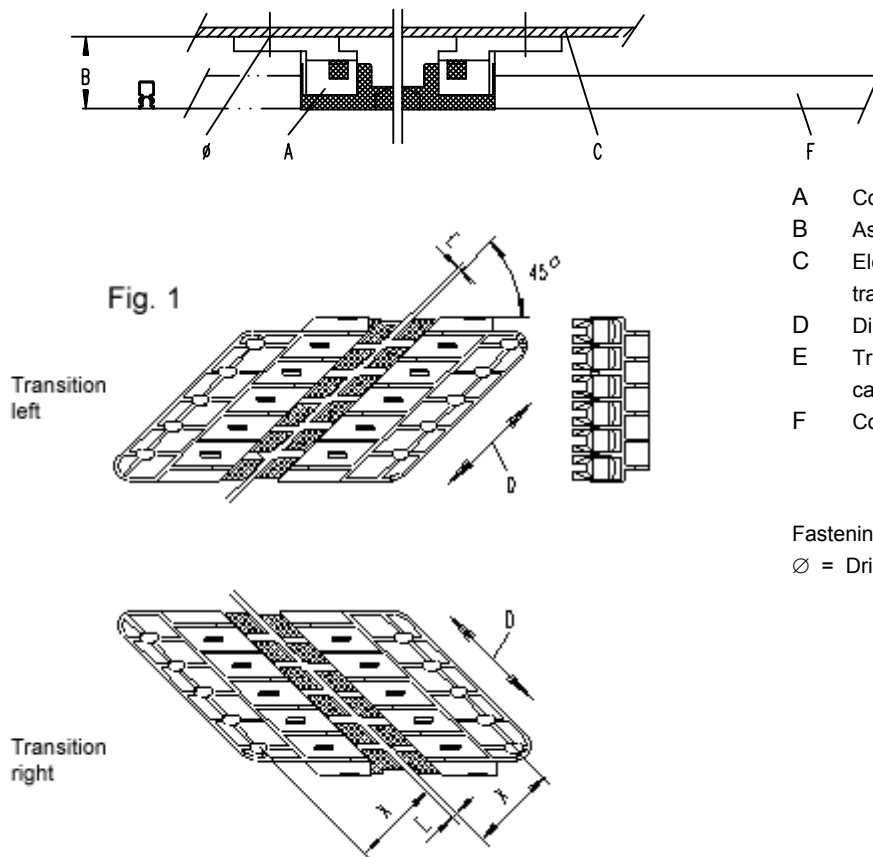
#### Fastening dimensions

Fig. 8 and 9:  $x = 28 \pm 5$  or  $55 \pm 5$  (optional)  
Fig. 10 for a displacement of  $45^\circ$ :  
Assembly height 27:  $Y = 50 \pm 5$ ;  $Z = 38 \pm 5$   
Assembly height 32:  $Y = 55 \pm 5$ ;  $Z = 33 \pm 5$   
Assembly height 40:  $Y = 63 \pm 5$ ;  $Z = 25 \pm 5$

$\varnothing$  = drill hole in "C":  
Assembly height 27 =  $7.2 + 0.3$   
Assembly height 32 =  $5.0 + 0.5$   
Assembly height 40 =  $5.0 + 0.5$



### Mechanical separation multiple-pole, 45°



- A Conductor rail transition complete
- B Assembly height 32 or 40
- C Electric suspended monorail or other trav.rail
- D Direction of displacement
- E Transition air gap max. 3 mm betw. the caps
- F Conductor rail FABA 30

Fastening dimensions:  $x = 48 \pm 3$  mm  
 $\varnothing =$  Drill hole in "C" =  $5.5 + 0.5$  mm

### Technical information

- The transitions left and right of 45° – cut angle for switches, for example **are identical to the transitions for conductor rails FABA 40 / 100**
- Refer to our list „Separations“ IS 100 U, pages 8 and 9
- Moreover, the following has to be taken into consideration:  
 The transitions may be used for all conductor rail types FABA 30, FABA 40 and FABA 100, even for any kind of combination, however, the supplied plug **cannot** be used for FABA 30

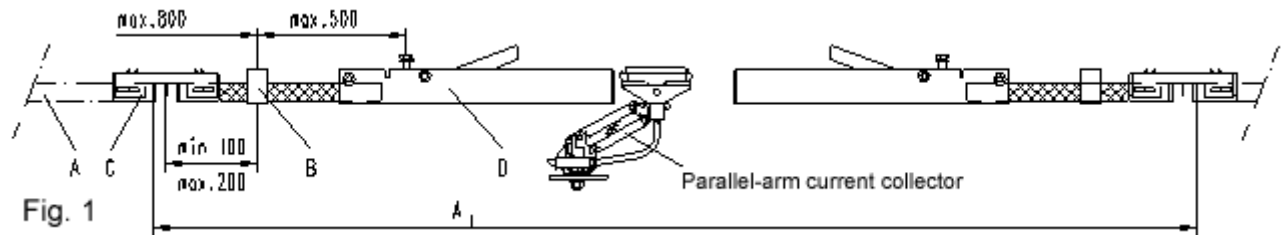
### Planning instructions

- Refer to our list „Separations“ IS 100 U, page 9
- Moreover, the following has to be taken into consideration:
  - combinations of FABA 30 with FABA 40 or FABA 100 in any order may be realised
  - for conductor rail FABA 30, the supplied plug cannot be used
  - thus, no power feeds for the 45° separation

### Installation instructions

- Refer to our list „Separations“ IS 100 U, page 9
- The following has to be considered when connecting the conductor rail FABA 30:
  - the conductor rails FABA 30 will fit into the transfer caps
  - the supplied plug cannot be used
  - thus, no power feed will be possible

### Mechanical separation Pick up guide



- A = Conductor rail FABA 30 or FABA 40 or FABA 100  
 A1 = Separation between the metal rails, length depends on the system.  
 B = Hanger clamp: one or multiple-pole, assembly heights on request.  
 C = Electrical separation FABA 30, see IS 100 C, page 10  
 FABA 40 / 100 see IS 100 B page 18  
 D = Multipole pick up guide: suitable for all parallel arm current collectors.

### Technical information

- The separation shown is **identical to the separation for conductor rails FABA 40 / 100**
- Refer to our list " IS 100 U pages 10 and 11
- Moreover, the following has to be taken into consideration:  
 the pick up guides can be used for all conductor rail types FABA 30, FABA 40 and FABA 100 and for each kind of combination
- The current collector has to pass the pick up guide without current, otherwise an arc will form at the separation point due to the ionisation with the air.

### Planning instructions

- Refer to our list „Separations“ IS 100 U, page 10
- The following has to be considered:  
 Combinations of FABA 30 with FABA 40 or FABA 100 in any order can be realised
- If a continuous power supply is required, at least two current collectors per conductor rail must be planned.

### Installation instructions

- Refer to our list „Separations“ IS 100 U, page 11



### Current collectors

For our conductor rail FABA 30

**all current collectors of the system FABA 100 are suitable** – see list IS 100 B Standard-Components -, i.e. the same current collectors have to be planned which are also required for the combinations with adjacent conductor rails FABA 40 / FABA 100.

For systems with pick up guides, plan parallel arm current collectors only.

In case of the connecting cables, you have of course to differentiate if the current collectors are used for power transmission, for control purposes or for the electronic data transfer.

### Data transfer

The conductor rail FABA 30 is suitable, due to its reasonable price, both for the transfer of electronic information/data and for the transfer of control signals.

Please consider that both the lines of the feeding components and the connecting cables of the current collectors have to be shielded. The cables are indicated in this list with the corresponding components.

### Pre-assembled conductor rail system

In list IS 100 V, we would like to present our advanced system:

The conductor rails FABA 40 / FABA 100 are completely assembled to the supporting, and running rails (e.g. for the electric monorail) with all accessory in the factory and transported to the location where their use is required. If for this use (or exclusively) , the FABA 30 conductor rail is planned, please contact us for further information

***Apart from a good planning of the conductor rail system, a correct and orderly installation is indispensable for the reliable operation and this not only for standard installations but also for extensively branched circuits – or for high travelling speeds, extreme fluctuations of temperature, etc.***

***Please, do not hesitate to contact us, if you need our assistance;  
Our experienced field agents are looking forward to supporting you with their long-standing experience.***

***For the realisation of the assembly work, we recommend to ask for our trained technicians – also to ensure the guarantee.***

***You can now rely on a partner with knowledge, competence and a long-standing experience.***



## Conductor Rail System FABA 100

for mobile equipment

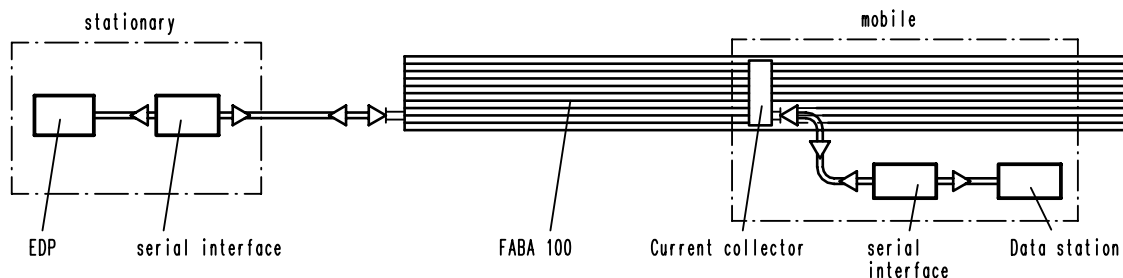
### Introduction

Our FABA 100 conductor rail system is not only suitable for the transmission of electrical energy but data may certainly be transmitted also; where one has to differentiate between the type of "data".

- For simple tasks such as the transmission of signals to the mobile equipment, e.g. to trigger control commands, the arrangement of electric or galvanic separation points within the conductor rail system is generally sufficient. The separating points are located in specially installed conducting rails - i.e. beside those required for the power transmission - they are to be equipped as simple electric interruption or with a separately fed rail section for example. Such separating points can be installed with our FABA 100 system without any problems at practically any point of the installation - also quite easy to be altered for different tasks. These electric separations may also be utilized for outdoor installations. All conductor rails - also the FABA 40 steel - can be used. As a rule current collectors with copper containing collector shoes are suitable for data transfer. One current collector is sufficient for the transmission of control commands. Please use standard components for this purpose according to list IS 100 B.
- In the course of the automation- and material-flow technique informations / data are to be transferred from a stationary computer via the conductor rail to a mobile data station. This certainly places the highest demands on the conductor rail system.

Now and then, even today, we meet with the prejudice that the transfer of data via conducting rails is "not to be achieved" with the assumption that misses. interruptions and other disturbances may occur and place doubts on its proper functioning.

However, we have been able - and that for many years - to prove under real conditions **that the transfer of data with our conductor rail system is carried out without any faults.**



### Insulated-Conductor-Rail System FABA 100

For the transmission of electric power and data to mobile equipment :

- \* For flawless bit-by-bit data transfer from stop to a traveling speed of 20 m/sec
- \* For the passing of multiplex data without time delay (real-time-transfer)
- \* For the transfer of signals from incremental and absolute path-measuring-systems
- \* For the passing of sensor-signals and control parameters
- \* Switches and branches can be realized
- \* Several operating devices or machines on the same installation may be supplied simultaneously with data by the appropriate number of conductor rails
- \* It is possible to transfer data during unidirectional traffic as well as during the reversing operation
- \* Use only in dry indoor spaces
- \* Application of the components : refer to this list "Selection of Components"
- \* e.g. for **Control units for shelves , electric monorails , handling equipment , mobile robots , crane Installations ,automated assembly lines**

*Based on our substantial experience we find the specific solution for every application.*

*We don't just recommend the listed components but develop and deliver individual components if required.*

*Our customers both at home and abroad value this service and our search for the optimized solution.*

*Our specialists are happy to be available for a personal meeting to discuss your requirements.*

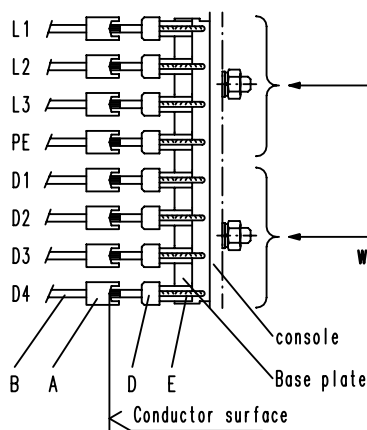
**FABA – a product of FAHRLEITUNGSBAU GmbH**

### General

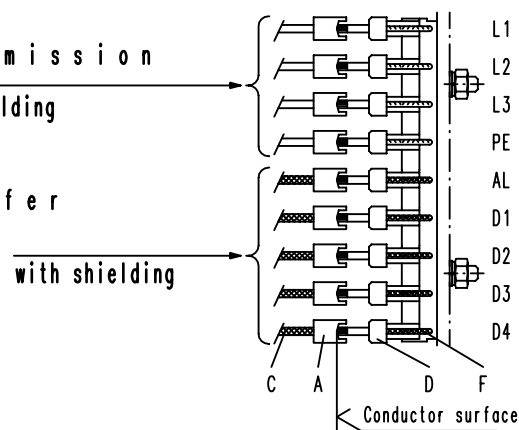
- The installation or layout and the selection of all FABA-components has to be planned very carefully.
- Correct installation is a prerequisite for a proper function –especially if high traveling speeds are planned. Data transfer in the sense of this list can only take place in dry indoor spaces.
- Provide only for a conductor rail center separation of 15 mm.
- Arrangement of the conductor surface facing down or sideways.
- Back and forth operation is possible.
- Permissible ambient temperatures – 30 °C to + 80 °C.
- Installations may also be equipped with pick up guides, i.e. with larger mechanical separations - refer to our list IS 100 U.

### Location of the Conductor rail system

**Fig. 1** Example 8 poles :  
Power transmission and data transfer  
without shielding

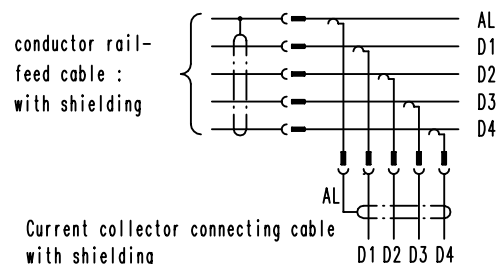


**Fig.2** Example 9 poles:  
Power transmission without shielding  
Data transfer with shielding



### Fig. 3 Shielding :

Connect the shielding of the conductor rail feed cables as well as the current collector connection cables with the cable AL so that they are electrically at the same potential. The conductor rail feed cable AL is to be Connected in accordance with the valid national regulations.



### Legend

- A Conductor rail corresponding to list IS 100 B :
  - for power transmission choice FABA 40 or FABA 100
  - for data transfer = FABA 100 - i.e. with copper metal rail
- B Fig. 1 Conductor rail feed cable :
  - for power transmission = corresponding to list IS 100 B - without shielding
  - for data transfer = corresponding to list IS 100 B - without shielding - 1.5 mm<sup>2</sup> is sufficient
- C Fig. 2 Conductor rail feed cable :
  - for power transmission = corresponding to list IS 100 B - without shielding
  - for data transfer = with shielding, refer to "Selection of Components" in this list
- D Current collector :
  - for power transmission = with copper carbon collector shoe
  - for data transfer = with silver carbon collector shoe
- E Fig. 1 Current collector connecting cable :
  - for power transmission and data transfer - without shielding
- F Fig. 2 Current collector connecting cable :
  - for power transmission = without shielding
  - for data transfer = with shielding "grey"

### Selection of Components

**Fundamentally:** Plan components according to list IS 100 B; also for installations in which data is transferred.

**Conductor rail:** For the transfer of data employ additional rails, but only FABA 100; metal rail of copper; standard- or heat-resistant insulation.

**Rail connector:** Plug-type and screw-type designs are both suitable.

**Conductor rail feed:** Splice joint- and / or End feed;

- Feed cable **without shielding** = cross-section of 1.5 mm<sup>2</sup> is sufficient
- Feed cable **with shielding** = state length when ordering **Order-No. 241 040 536**  
Design: one side with cable lug for M6; single-core, highly flexible; standard shielding; outer-Ø 5.1 (PVC grey); impedance 75 Ohm.

**Expansion:** Plan components from list IS 100 B.

**Electrical separation:** Usually not required for the transfer of data in the sense of this list.

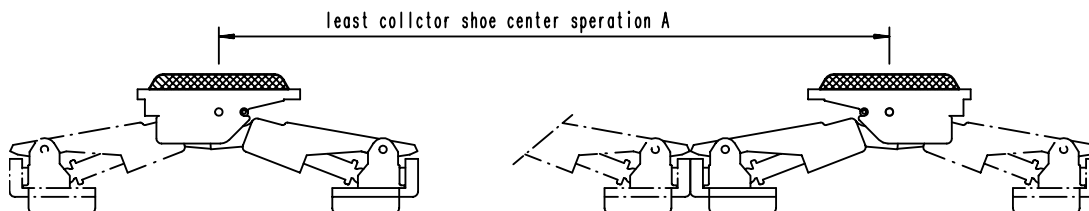
**Mechanical separation:** May also be planned for data transfer;

- With transfer caps for switches, shunting stages, lift sections and similar.
  - 1) In one-pole design corresponding to list IS 100 B, may also have a feed-in;
    - 1a) Feed cable **without shielding** = cross-section of 1.5 mm<sup>2</sup> is sufficient
    - 1b) Feed cable **with shielding** = state length when ordering **Order-No.241 040 535**  
Design: one side with cable lug for M5; single-core, highly flexible; standard shielding; outer-Ø 5.1 (PVC grey); impedance 75 Ohm.
  - 2) In multi-pole design corresponding to list IS 100 U with "straight caps", may be fed-into, as before - refer to 1).
  - 3) In multi-pole design corresponding to list IS 100 U with "bevel-cut caps", may also be fed-into;
    - 3a) Feed cable **without shielding** = cross-section of 1.5 mm<sup>2</sup> is sufficient
    - 3b) Feed cable **with shielding** = state length when ordering **Order-No. 241 040 497**  
Design: one side with plug; single-core, highly flexible; standard shielding; outer-Ø 5.1 (PVC grey); impedance 75 Ohm.
- with pick up guides for larger conductor rail interruptions (list IS 100 U).

**Current collector:** Principally use a one-arm data current collector with **silver collector carbon**.

- Current collector connection cables without or with shielding corresponding to list IS 100 B;
- For traveling speeds up to 40 m/min or 0.67 m/sec usually only **one current collector is required for each conductor rail**;
- For higher traveling speeds we recommend to provide **2 current collectors for each rail** to maintain a continuous contact. Spacing of collectors depends on travelling speed.  
Two current collectors are - whether pulling or pushing is unimportant - to be located in such a way that the following minimum distances from the center of the collector shoe to the opposite collector shoe are maintained.

**Please Note:** on request we can deliver type HF shielded coaxial cable



	Traveling speed [ m/sec ]						Higher traveling speeds may be realized , however we suggest you contact us for assistance.
	to 2	3	4	5	6	7	
Collector shoe center sep. min. A [ mm ]	110	190	270	340	420	500	



## Conductor Rail System FABA 100

for mobile equipment

### General

Hanger clamps serve to fasten the conductor rails to a beam.  
Screw-type hanger clamps for general use are listed under components IS 100 B.  
Beyond that we have developed further hanger clamps for the most diverse applications, most of which are kept in stock, they are shown in this list.

### Technical Information

Valid for all hanger clamps shown in this list- unless stated otherwise :

- Body of clamp one unit, made of polycarbonate plastic, colour orange.
- For conductor rail centre separation 15 mm.
- Permissible ambient temperatures - 30°C to + 80°C.
- The clipped-in conductor rails slide in the hanger clamps allowing expansion in length.
- **Important** : Hanger clamps with adhesive tape can only be stored for approx. 1½ years.
- The hanger clamps shown in this list have largely been developed for special profiles of various electric monorails, - for the most part they are clipped-in. We forego to state detailed measurements because the perfect fit can only be determined with an original profile. For this reason we require a sample of unknown profiles, we can supply you with a sample clamp if requested.

### Planning Instructions

- The assembly height has to be observed at all times.
- For assembly heights of 32 mm or more, control cables can be installed through openings in the hanger clamps.
- The rails (ground) may be located at arbitrary points.
- Hanger distances : In straight sections max. 800 mm, in bends max. 400 mm; to the ends of the conductor rails min. 100 mm, max. 300 mm, also refer to the basic diagram of list IS 100 B.

### Installation Instructions

- Depending on the installation, the hanger clamps are fastened directly or by means of consoles to the track / rail; they have to align correctly.
- The conductor rails are simply pressed into the hanger clamps until they audibly snap-in.
- The conductor rail can be taken out of the hanger clamp at any time :  
Push the sides of the clamp apart ; for extensive installations we recommend to use the rail removal wedge – refer to list IS 100 B = hanger clamps.

#### Structure of the list

Hanger clamps	screw-type,	assembly height 27 mm assembly height 32 mm assembly height 40 mm
	clip-type ,	assembly height 27 mm assembly height 32 mm assembly height 40 mm
	others ,	assembly height 27 mm assembly height 32 mm assembly height 40 mm

#### Fastenings

**FABA – a product of FAHRLEITUNGSBAU GmbH**

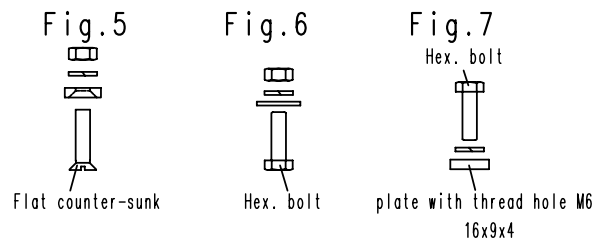
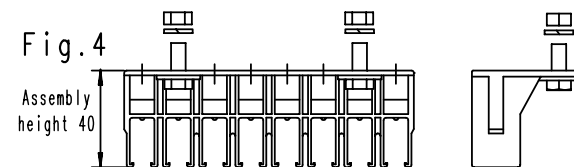
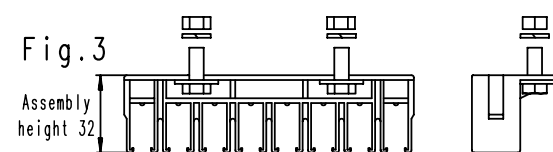
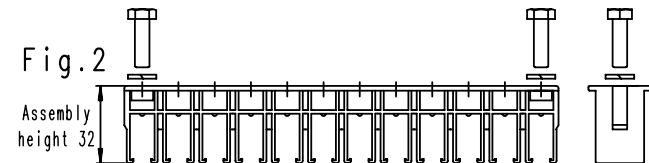
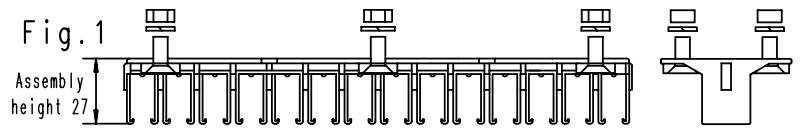
### Hanger-Clamp screw-type assembly

Order-No.				Weight
241 006 138	2-poles	Fig. 1	Height 27 mm	0,008
241 006 129	3-poles			0,012
241 006 128	4-poles			0,015
241 006 127	5-poles			0,019
241 006 137	6-poles			0,023
241 006 126	7-poles			0,026
241 006 130	8-poles			0,030
241 006 131	9-poles			0,034
241 006 132	10-poles			0,038
241 006 133	11-poles			0,042
241 006 134	12-poles			0,045
241 006 135	13-poles			0,049
241 006 136	14-poles			0,053

Order-No.				Weight
241 009 211	2-poles	Fig. 2	Height 32 mm	0,006
241 009 212	3-poles			0,009
241 009 213	4-poles			0,012
241 009 214	5-poles			0,015
241 009 215	6-poles			0,018
241 009 216	7-poles			0,021
241 009 217	8-poles			0,024
241 009 218	9-poles			0,027
241 009 219	10-poles			0,030
241 009 220	11-poles			0,033
241 009 210	12-poles			0,036

Order-No.				Weight
241 006 017	8-poles	Fig. 3	Height 32 mm	0,030

Order-No.				Weight.
241 009 223	4-poles	Fig. 4	Height 40 mm	0,020
241 009 224	5-poles			0,025
241 009 225	6-poles			0,030
241 009 226	7-poles			0,035
241 009 227	8-poles			0,040



Order-No.	Fig.				Weight	
241 013 003	5	Screw Set M6 x 25	für clamp fig. 1	with washer orange, spring washer and nut;	set; zinc-plated, in bag	0,010
241 013 001	6	Screw Set M6 x 20	for clamp fig. 3+4	with spring washer and nut;	set; zinc-plated, in bag	0,008
241 013 022	7	Screw Set M6 x 12	for clamp fig. 2	with washer, spring washer and plate with thread hole	set; zinc-plated, in bag	0,008
241 013 023		Screw Set M6 x 16				0,009
241 013 024		Screw Set M6 x 20				0,010

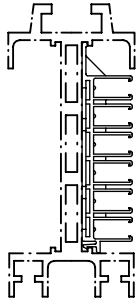
### Technical Information

- Permissible continuous ambient temperatures:  
- 30 °C to + 80 °C.
- Center separation 15 mm.

**Hanger clamps** are delivered without screw material. If M6 accessories are required, we request you to inform us about the type. The number of screw connections depends on the type of hanger clamp and the number of poles. The drawings show examples of screw-fastenings.

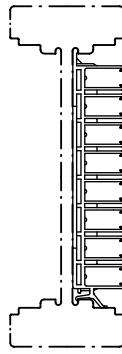


### Hanger - Clamp Clip-type - Assembly height 27 mm



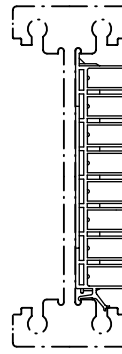
6 poles

Order no. 241 000 423



8 poles

Order no. 241 007 010



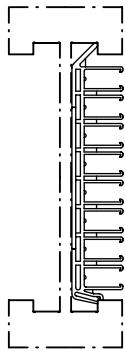
8 poles

Order no. 241 007 020



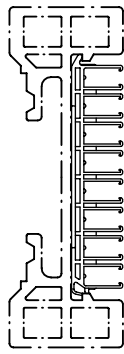
8 poles

Order no. 241 007 020



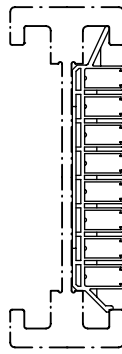
8 poles

Order no. 241 007 091



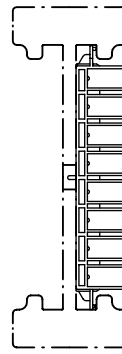
8 poles

Order no. 241 007 065



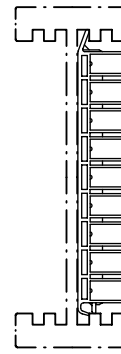
8 poles

Order no. 241 007 098



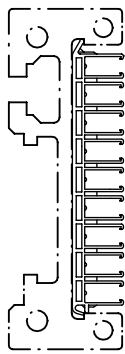
8 poles

Order no. 241 006 050  
(without adhesive strip)



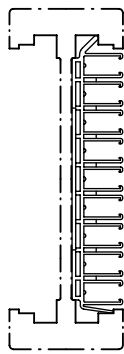
9 poles

Order no. 241 007 102



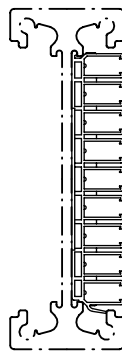
9 poles

Order no. 241 007 099



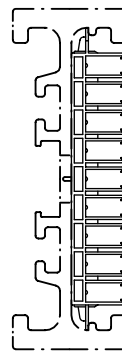
9 poles

Order no. 241 007 104



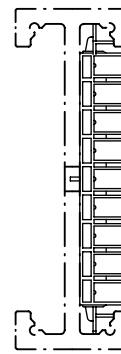
9 poles

Order no. 241 007 107



9 poles

Order no. 241 006 147  
(without adhesive strip)



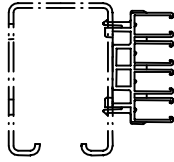
9 poles

Order no. 241 008 000  
(without adhesive strip)

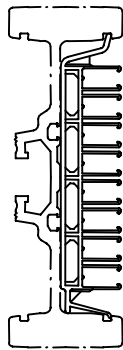
### Technical Information

All hanger clamps are precisely matched to the AMS-profile ; the backsides are provided with a durable adhesive strip at the factory , to prevent lateral slip in the AMS-profile (AMS = Automated Monorail System).  
Hanger clamps with adhesive strip can only be stored for max. 1 ½ years.

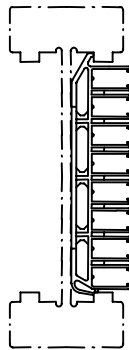
### Hanger - Clamp Clip-type - Assembly height 32 mm



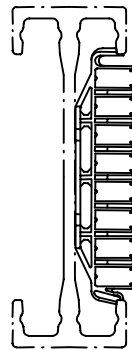
4 poles  
Best.-Nr. 251 003 605  
(without adhesive strip)



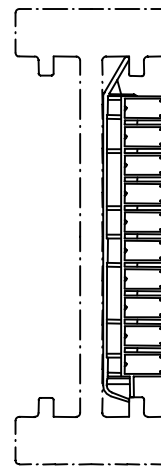
8 poles  
Best.-Nr. 241 007 106



8 poles  
Best.-Nr. 241 006 030



8 poles  
Best.-Nr. 241 007 050

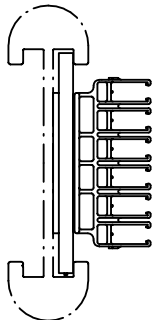


10 poles  
Best.-Nr. 241 009 107

#### Technical Information

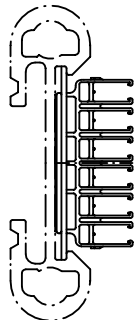
All hanger clamps are precisely matched to the AMS-profile ; the backsides are provided with a durable adhesive strip at The factory , to prevent lateral slip in the AMS-profile (AMS = Automated Monorail System).  
Hanger clamps with adhesive tap can only be stored for max. 1 ½ years.

### Hanger - Clamp Clip-type - Assembly height 40 mm



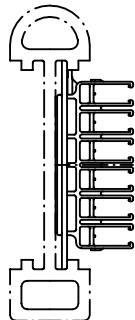
6 poles

Best.-Nr. 241 004 023



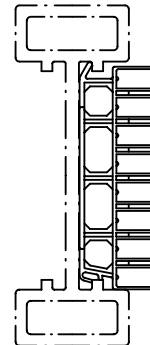
6 poles

Best.-Nr. 241 004 016



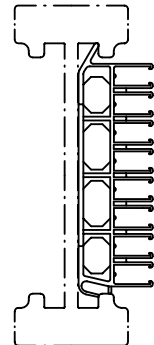
6 poles

Best.-Nr. 241 004 015



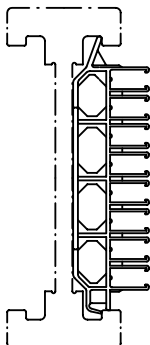
8 poles

Best.-Nr. 241 007 092



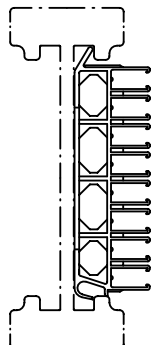
8 poles

Best.-Nr. 241 007 015



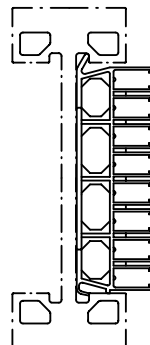
8 poles

Best.-Nr.  
241 007 093



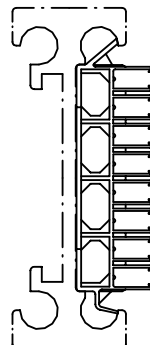
8 poles

Best.-Nr.  
241 007 105



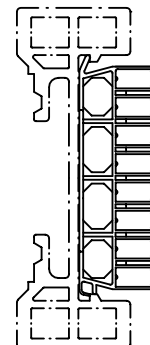
8 poles

Best.-Nr.  
241 007 085



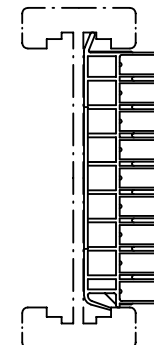
8 poles

Best.-Nr.  
241 007 094



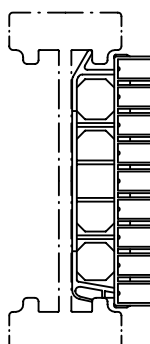
8 poles

Best.-Nr.  
241 007 111



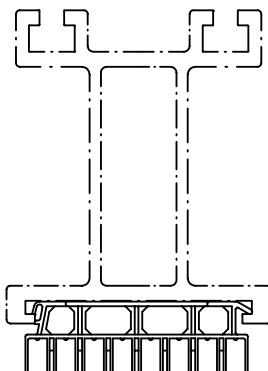
9 poles

Best.-Nr.  
241 007 110



9 poles

assembly height 45 mm  
Best.-Nr. 241 007 097

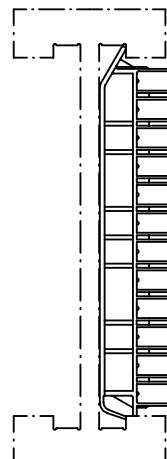


8 poles

Best.-Nr. 241 007 092

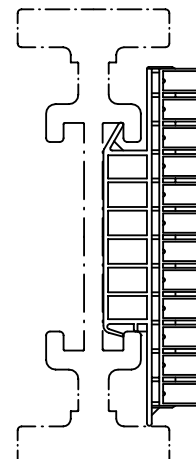
9 poles

Best.-Nr. 241 007 025



12 poles

Best.-Nr. 241 009 108



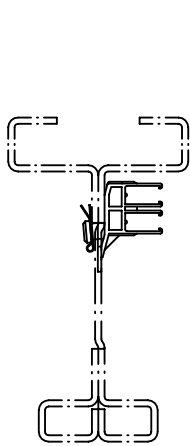
12 poles

assembly height 52 mm  
Best.-Nr. 241 009 106

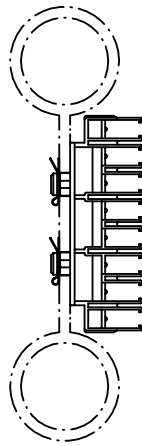
#### Technical Information

All hanger clamps are precisely matched to the AMS-profile ; the backsides are provided with a durable adhesive strip at The factory , to prevent lateral slip in the AMS-profile (AMS = Automated Monorail System).  
Hanger clamps with adhesive tap can only be stored for max. 1 ½ years.

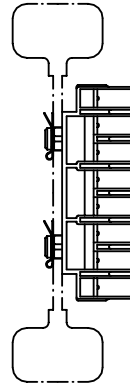
### Hanger – clamp    Stud – mounting with spring clip



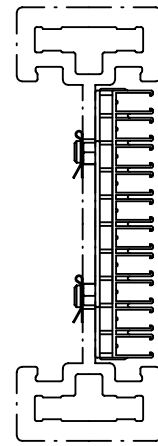
2 poles  
assembly height 32 mm  
Order No. 241 000 422



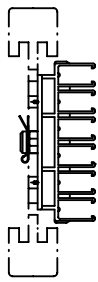
8 poles  
assembly height 40 mm  
Order No. 241 007 055



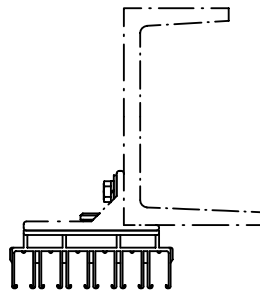
8 poles  
assembly height 40 mm  
Order No. 241 007 005



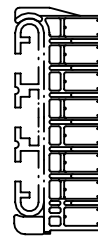
10 poles  
assembly height 32 mm  
Order No. 241 009 005



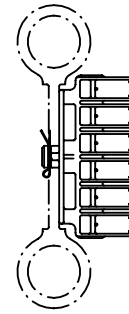
6 poles  
assembly height 32 mm  
Order No. 241 004 022



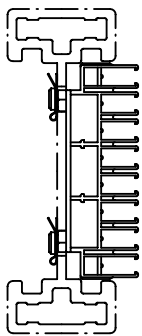
6 poles  
assembly height 32 mm  
Order No. 241 013 012



8 poles  
assembly height 32 mm  
Order No. 241 006 005



6 poles  
assembly height 40 mm  
Order No. 241 000 418



8 poles  
assembly height 40 mm  
Order No. 241 007 000



2 poles  
assembly height 32 mm  
Order No. 241 000 421

### Technical Information

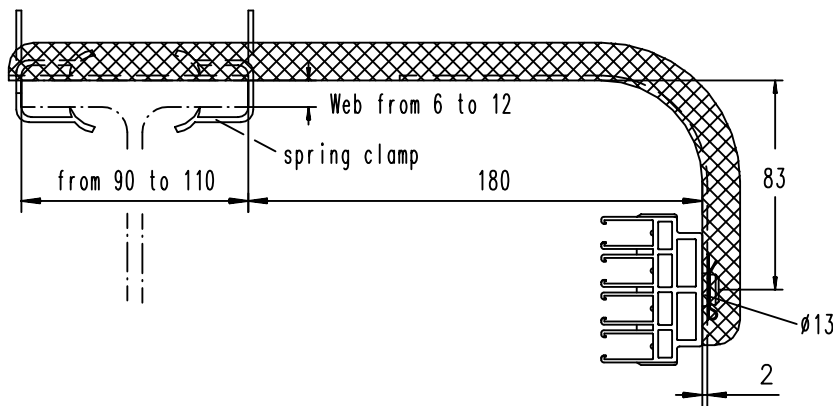
The hanger clamps are fastened with their bolts to the AMS-rail-web by means of spring clips.  
(except order no. 241 006 005)

### Fastening-Consoles

In the following a few consoles out of our program :

The sketches also as an inspiration on how the fastening of hanger clamps may eventually be solved in a similar manner. Shown are the hanger clamps for the insertion- /quick-mounting, the screw-types -depending on local conditions - may be employed in a similar way .

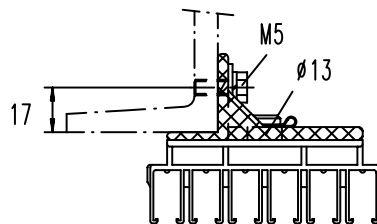
We are certainly prepared to develop new consoles to specifications , feel free to ask us .



**Fig. 1**

Fastening with solid sheet-metal console for quick installation ;

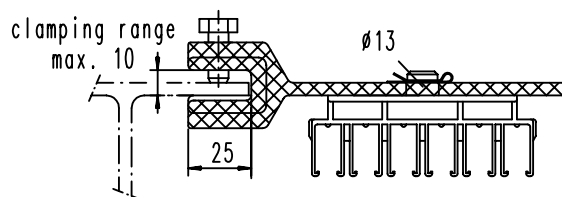
Hanger-clamp e.g. 4 poles  
Art.-No. 241 003 601



**Fig. 2**

Fastening with a plastic console screwed to a girder ;

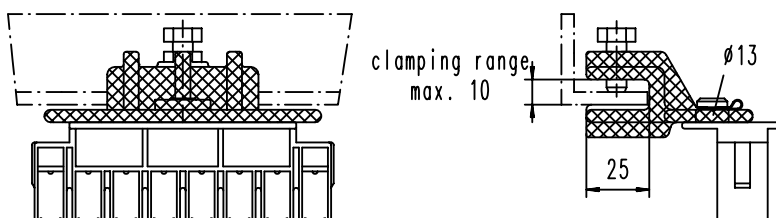
Hanger clamp e.g. 6 poles



**Fig. 3**

Fastening with Al –cast console clamped to a girder

Hanger clamp e.g. 6 poles



**Fig. 4**

Fastening with Al –cast console clamped to a traverse

Hanger clamp e.g. 8 poles



## Conductor Rail System FABA 100

for mobile equipment

### Introduction

Basically, the collector shoes of the different current collectors of our system are designed as a single replaceable component part – they are subject to wear.

This **wear** is different from installation to installation, since it is caused by a variety of influences, e.g. the existing ambient temperatures, additional heat caused by the energy transfer at the conductor rail, atmospheric humidity, travelling speeds, the frequency of „stop and go“, the number and kind of curves and bends to be travelled, the number of conductor rail interruptions like expansion points, electrical separations, switches, lifting devices etc.

Therefore, it might absolutely be possible that even within an individual installation, the collector shoes – e.g. at the individual running gears in case of an electric suspended rail – are differently worn. Even at the same running gear, the collector shoes may indicate a different wear as PE-current collectors do not need to pass electrical interruptions.

As you may understand, indications concerning „Stop intervals/travelling performances“ of our collector shoes cannot be made due to the aforementioned reasons. A very global standard value may be, according to our experience, 15.000 – 20.000 km. However, it has to be taken into consideration that the collector shoes are more intensely worn during the start phase in case of a new installation, than later when the metal rail has become smoother and the splices/transitions are more run in and furthermore, a certain – frequently favourable – layer of patina has formed on the collector surface.

In order to prevent a standstill due to worn or broken collector shoes, **they have to be inspected:**

- a) Continuous manual inspections and a „registration“, if necessary, of each single collector shoe is often not very economical and frequently leads to the unacceptable safety measure of „collector shoe replacement“ although the limit of wear is not reached by far. However, manual inspections do not exclude the fault that malfunctions caused by worn collector shoes will occur. Such malfunctions will not only lead to unpleasant standstills but they may also have a negative impact on the collector surface of the conductor rails as in case of an insufficient power transmission heat damages may be caused.

If this is the case, the collector surfaces of the complete system will have to be verified and the damages will have to be eliminated, as, even by using new collector shoes, a sufficient power transmission cannot be ensured, at least, an accelerated wear of the collector shoes will have to be expected.

**It is, however, possible to do without complicated manual inspections!**

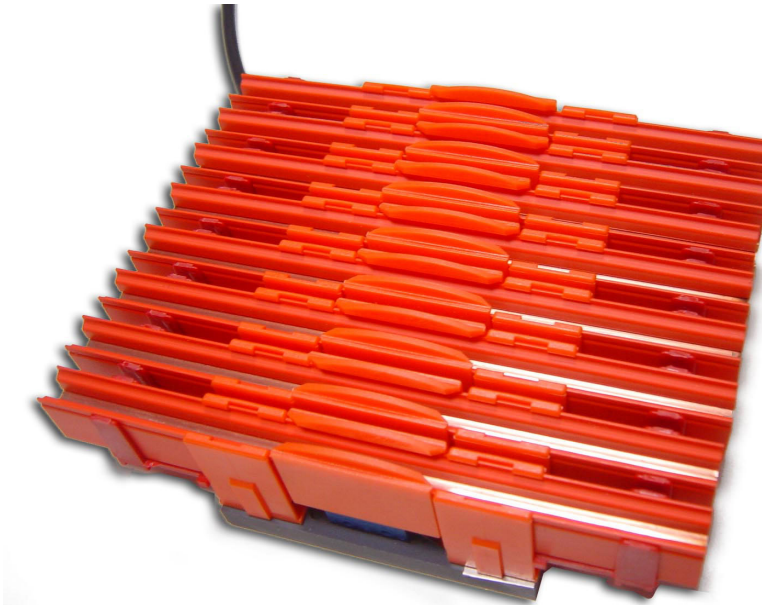
- b) **We offer automatic checking and inspection devices.**

If the collector shoe passes such a checking device or station, the state of the collector shoe will be automatically and reliably checked and monitored, manual inspections will be no longer necessary.

Unacceptably worn or broken collector shoes or the fleece of the cleaning shoe are recognised by the device and will be immediately indicated. This indication can be interpreted in different ways, e.g. by switching off the subsequent section in case of simple systems, by activating the subsequent switch in case of branched systems, which are usual for the electric suspended monorail, which puts the vehicle out of operation. In general, one checking device per system will be sufficient, if it is ensured that all vehicles/collector shoes are monitored as often as possible.

## FABA – a product of FAHRLEITUNGSBAU GmbH

### Collector shoe wearing tester



**Order No.**

**To be supplied on**

**request only**

This testing device to verify the wear of the collector shoe will only be fabricated individually according to the local conditions of use.

In your request, please state the following:

- Which current collectors are used?
- How is the conductor rail center distance (usually 15 mm)?
- Which hanger clamp is used for your system or how is the assembly height?
- In case of an electric monorail, please specify the form of the monorail
- If it is not an electric monorail: Which fastenings are used or should be used?
- No. of poles that are to be monitored?
- Length of the connecting cable (usually 2 m)

### Working mode

At the control point, the plunger, clipped on the continuous conductor rail, will be mechanically lifted by the passing current collector head. The more the carbon of the collector shoe is worn, the more the plunger will be lifted. If a specified value is exceeded, i.e. if the collector shoe is worn to the permissible extent, the microswitch responds and will guide, e.g. for the control of a switch, to a by-pass section.

The cleaning shoes are monitored in the same way.

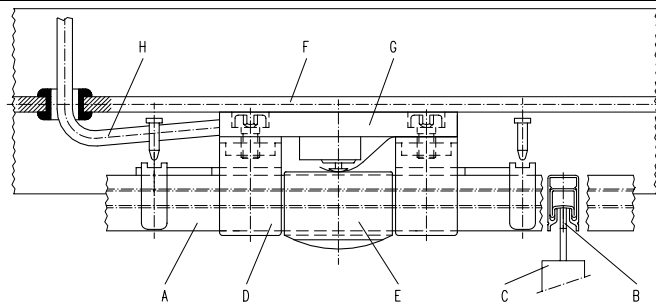
The adjacent figure shows the basic structure.

The installation of one plunger on each of the adjacent conductor rails can be selected.

We recommend the monitoring of all current collectors, as the wear on the individual rails may differ considerably.

This mechanically/electrically operating wear testing device for the collector shoes has a trouble free function with one moving part.

After a correct assembly, it works reliably and can easily be maintained.



- A = Continuous conductor rail
- B = Collector shoe
- C = Head of the current collector
- D = Clamp for the conductor rail(s)
- E = Plunger; 1 piece per pole / conductor rail;

will be lifted by C and will then spring back into its original position

- F = Fastening: e.g. conductor rail web of the electric monorail; with recess and fastening holes
- G = Switch plate, adjustable, 1 microswitch

per pole / conductor rail

- H = Connecting cable; 2m long, firmly connected  
2 x 0.75 mm<sup>2</sup>, H03VV - F für 230 Volt



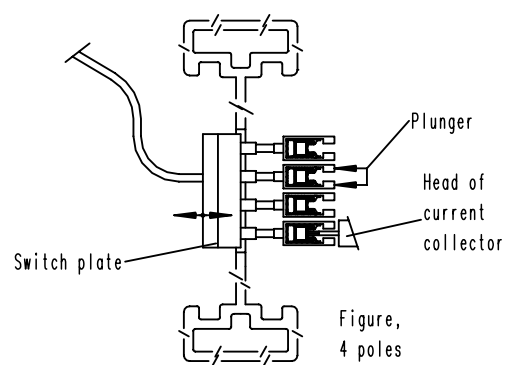
### Collector shoe wearing tester Continuation

#### Technical information

- The collector shoe wearing tester is basically suitable for all listed current collectors (including cleaning shoes)
- The switches including the corresponding wiring has the system of protection IP 4X, i.e. it is only suitable for dry interior spaces
- The permissible ambient temperatures are - 30 °C up to + 70 °C, i.e. this means a slight deviation compared to the heat-resistant insulation
- The testing device and our standard components are of equal chemical resistivity
- Suitable for travelling speeds up to 75 m/min., and back and forth operations
- Suitable for conductor surfaces facing down or sideways

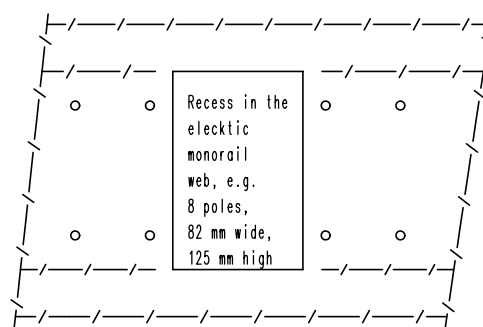
#### Planning instructions

- In general, one collector shoe wearing tester per system will be sufficient, if possible, directly preceding a by-pass/maintenance section, at a point which will be passed by the current collectors.  
If one of the microswitches reacts, e.g. the switch to the maintenance section can be controlled and the vehicle can be separated.
- In case of an electric monorail, the testing device is fastened to the web of the running rail. On one side, the conductor rails and the probe are clipped on and on the opposite side, the switch plate is screwed down. The switches scan the probes through a relatively large recess (please consider that a possible weakening of the monorail may occur).
- The conductor rails slide in the control station, therefore, the distance to the rail connector, etc. must be min. 100 mm



#### Installation instructions

- Each testing device will be supplied with exact instructions for cut-out dimensions and installation procedure if required  
A correct assembly is indispensable for a reliable operation of the testing device.



#### Maintenance

- The functioning of the testing device must be regularly checked:  
In particular, the movability of the plungers, they must not be tilted or get jammed!  
Do the springs which press back the plunger work properly?  
Do the microswitches work properly?
- A contamination has to be avoided. We recommend the use of a cleaning aggregate, refer to special list IS 100 S
- Clean using air pressure nose



## Conductor Rail System FABA 100

for mobile equipment

### Introduction

Dust collecting over a period of time - even though our plastic components are largely antistatic - make the system comparably unsightly, i.e. the orange signal color loses its brilliance, which, in general, does not influence the quality of the conductor rail system.

One has to distinguish between system- and externally generated dusts.

**Dusts generated** by the system are those caused by the wear of the collector shoes.

The collector shoes of the current collectors contain a large amount of copper or silver, as for the case of data transfer. However, they contain an appreciable amount of graphite, which is released during the wearing process and advantageously collecting in form of a patina on the surface of the conductor, reducing the friction, as well as graphite particles being raised by the moving current collectors or vehicles and subsequently being deposited on various components. It often comes to pronounced deposits of graphite especially at mechanical interruptions of the conductor rails (expansion points, separation- and transfer caps). This blackening of the components must not be a cause for alarm, - apart from the optics - **it does not negatively affect** the technique of the conductor rail system.

**Externally generated dusts** are those generated outside the conductor rail system - mostly through production processes. As floating particles they deposit themselves on the FABA-system, and are partly blown up again by the wind of moving equipment (e.g. AMS) and can in time be distributed throughout the complete system. Since these dusts are of different sizes and may consist out of the most diverse materials, It has to be determined in the individual case whether detrimental effects to the conductor rail system are to be expected; usually, dusts generated by the system, do not have a negative effect on the technical components.

However, **harmful dusts** do indeed exist; from our experience over many years we name in particular:

- a) unusually strong emissions,
- b) if they are also very conductive and
- c) if they are fibrous, perhaps even relatively long.

Especially the dusts mentioned under c) may be very light, thus may be raised quite easily; they deposit themselves also on the conductor surface, for example, and - since they are mostly non-conductive – lead to contact problems.

It has to be mentioned that the dusts generated by the system as well as the dusts from external sources, depending on the type of operation and intensity, may be detrimental :

- a) to the personnel,
- b) as deposits on finished products and
- c) to the reliability of the conductor rail system.

**As a solution we offer our Dust-Removal-System**, - which may also be applied in other conductor-rail-systems.

Remark: We view the possibility of cleaning the conductor rail system of dusts by blowing or brushing as being of superficial use only because in most cases the dust, after having been raised, will deposit itself on the conducting rail system again.

Our recommendation - however more elaborate - is quite clear :

We consider the best method is to **vacuum and collect the deposits**.

## FABA – a product of FAHRLEITUNGSBAU GmbH

### Vacuum and accessories

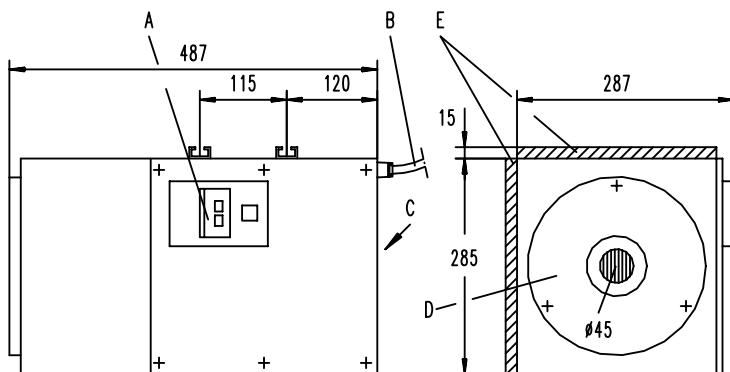


Fig. 1

- A = (fig. 1) motor protection-switch
- B = connection cable, length 1.5 m
- C = exhaust-air screen opening
- D = suction nozzle, removeable for cleaning the filter
- E = (fig. 1) C-rails, 28 x 15, for fastening / supporting; location on two sides
- F = (fig. 2) fastening / supporting, M10
- G = (fig. 2) on- / off switch

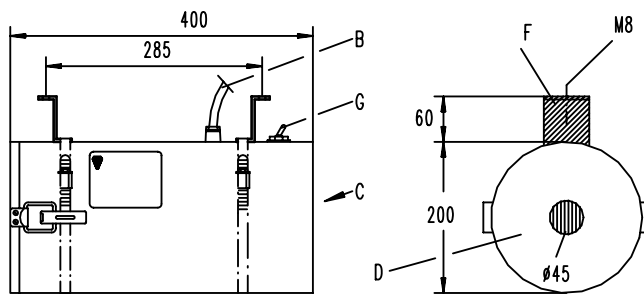


Fig. 2

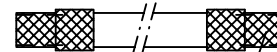


Fig. 3

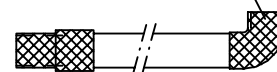


Fig. 4

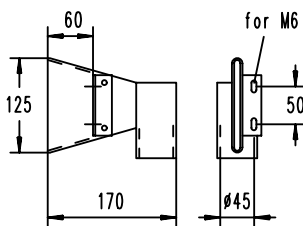


Fig. 5

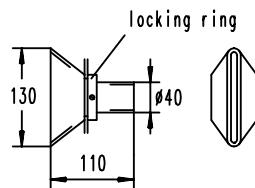


Fig. 6

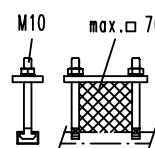


Fig. 7

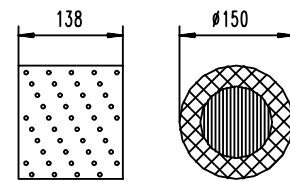


Fig. 8

Order-No.	Fig.	Identification		Weight	
241 047 ***	1	Vacuum, angular	Suction 20 m <sup>3</sup> /h	*** State operating- and control voltage	
241 047 955	2	Vacuum, round	Suction 155 m <sup>3</sup> /h	Operating voltage 230 V, 1 ~, 50/60 Hz	
241 047 951	3	Suction hose	Plastic; flexible; length 1.5 m, can be shortened; (other lengths on request)	0,610	
241 047 950	4	Suction hose		0,700	
241 047 924	5	Suction nozzle		Hard-PVC; example shown, 8-pole (different no. of poles and different mounting on request)	0,310
241 047 960	6	Suction nozzle			0,150
241 047 200	7	Fastening	for mounting of vacuum, fig. 1; 4 bolts, 2 clamps	0,800	
241 047 901	8	Filter	Permanent filter; fits vacuum of figs. 1 and 2 1 set for vacuum motor, corresp. to fig. 2	as spare only	
241 047 903	no	Carbon		0,810 0,036	

### Vacuum and accessories - Continuation - Procedure

The vacuum is mounted on the mobile equipment, the suction nozzle is located in front of the conductor rails. While moving through the installation, the dust deposited as well as the dust generated by the current collector will be sucked off. To keep the system clean, we recommend a regular vacuuming, so that from this point of view no disruptions are to be expected.

The vacuum takes its electrical power from the conductor rails.

The angular vacuum corresponding to fig. 1 may be controlled such that it only vacuums during movement; it is designed for continuous operation.

Its major application is found in branched systems, automated operation, or, if descending dust effects the production below and / or computer aided transfer of data takes place.

### Technical Information

- a) Vacuum, angular corresponding to fig. 1 :
  - Power 0.55 kW; **100 % duty cycle**; 1200 mm water column
  - Operating voltage, preferably 42/230/400 V, 3 ~, 50 Hz; other voltages, also 1-phase, also 60 Hz by request
  - Control voltage, preferably 24 V = or 24/42/220/380 V ~ 50 Hz; other direct- or alternating currents, also 60 Hz, also without control, by request
  - Fig. 9 shows a common type of wiring;  
Remark: For operating voltages up to 42 V a soft-start will be installed to reduce the otherwise high start-up currents
  - containing an externally accessible motor protection switch with operating indicator
- b) Vacuum, round corresponding to fig.2 :
  - Power 0.9 kW; **50 % duty cycle**; 2300 mm water column
  - Operating voltage 220 V, 1 ~, 50/60 Hz
  - Fig. 10 shows the corresponding wiring
  - with on- / off switch
- c) for both vacuums :
  - Permissible ambient temperatures – 20 °C to + 50 °C; i.e. slight deviation as compared with our other components.
  - Chemical resistant as for our other components.
  - Suitable for use with all traveling speeds.
  - Protection type IP 42
  - with impact-resistant housing, grey
  - sound absorbing finish
  - connection diagram will be supplied
- d) Suction nozzle :
  - of impact-resistant plastic
  - Figs. 5 and 6 show our standard designs; because the equipment / drives as well as the mounting environment and the local conditions may be quite different from case to case, we can offer additional suction nozzles. Should you experience difficulties with our standard-nozzles, we ask you to furnish us with further details :  
number of poles of the conductor rail; sketch containing the available space and the types of fastening required
- e) Fastening / support :
  - Vacuum, angular corresponding to fig. 1  
with our standard-design we offer the solution shown in fig. 7; the 4 clamping bolts with the 2 clamps are inserted into the C-rail of the vacuum (location selected on one of the two sides); they are suitable to be clamped to a AMS carrier-girder for example; other types of mounting by request
  - Vacuum, round corresponding to fig. 2  
2 Alu-brackets are fastened to the vacuum, complete with nuts and bolts M8
- i) Filter:
 

Both vacuums are shipped complete with installed filter; it holds approx. 1 Liter.  
The filter has been designed for continuous operation; it consists of a metal bottom and a metal basket with a protectively inserted pleated filtercloth.  
For cleaning purposes the plate with the hose connection has to be removed (no tools required).  
Beware that the dust does not fall out prematurely !  
The filter **is to be emptied dry / suck out with small household vacuum cleaner**  
We recommend to obtain a spare filter for direct exchange and also because damage over a eriod of use cannot be excluded.

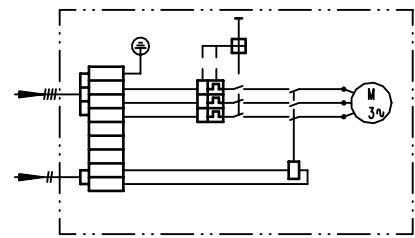


Fig. 9

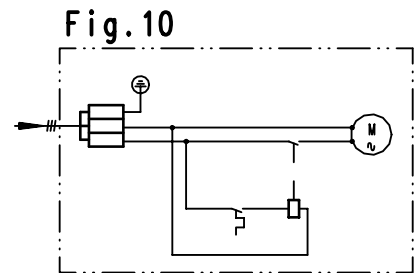


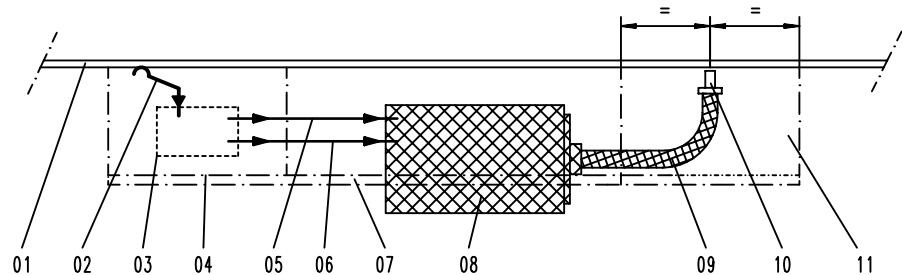
Fig. 10

### Vacuum and accessories - Continuation -

#### Planning Instructions

- The equipment usually remains on the installation.
- The location is carried out in accordance with local conditions, e.g. for Electric-Mono-Rails opportunistly on a spare- or production vehicle, below or on the side of the load girder or also above the rail.
- In principal the vacuum can be operated in every mounting position, with one exception, the suction nozzle "D" (figs. 1 and 2) must not be located underneath (as the dust falls back into the nose when not vacuuming).
- Care has to be taken for the exhaust-air screen opening remains unobstructed, that the suction hose is not kinked, and the plate with the hose connection remains accessible to change the filter as well as the motor protection switch or the on- / off switch.

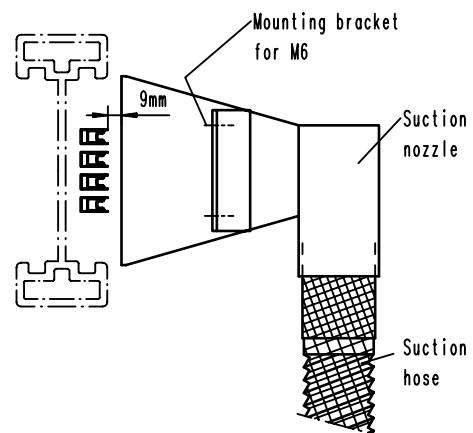
**Fig. 11**  
**Principle-Location**  
e.g. on an AMS  
(Automated Monorail  
System)



- 01 = Conductor rail
- 02 = Current collector
- 03 = Switch box on EMR-vehicle
- 04 = AMS-drive
- 05 = Operating voltage to vacuum - at the switch box "03" to be plugged if possible
- Important** The additional power required by the vacuum is to be considered in the layout of the switch box and especially the current collectors.
- 06 = Control voltage for turning the vacuum on / off - also refer to fig. 9
- 07 = Load girder
- 08 = Vacuum; mounted to load girder
- 09 = Suction hose
- 10 = Suction nozzle = center support- / idler roll, 9 mm distance to conductor rail
- 11 = AMS - follower

#### Installation Instructions

- a) Vacuum, angular corresponding to fig. 1: is equipped with C-profiles for individual mounting / support, fitting for bolts M10 (fig. 7).
  - b) Vacuum, round corresponding to fig. 2: has two metal brackets including nuts and bolts M8 for mounting / support.
- C Suction nozzle:  
Mounting on mobile equipment with a distance of 9 mm to the conductor rails.  
Care must be taken that, for installations containing bends, the nozzle is to be located at center of a guide roller if possible.  
Prepared for individual mounting.  
Care must be taken that the nozzle opening is not pinched and restricted when bolted on.





## Conductor Rail System FABA 100

for mobile equipment

This list supplements the list of the FABA 100 conductor rail system "Standard Components" IS 100 B where our standard transfer caps for mechanical conductor rail separations are also shown.

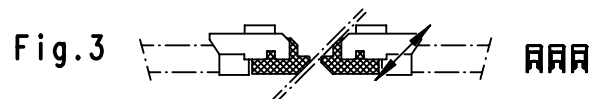
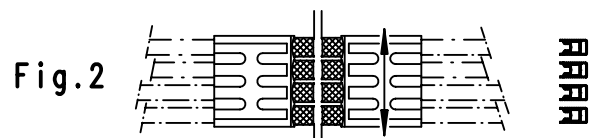
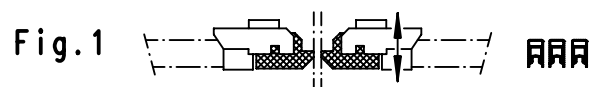
**Mechanical separations of the conductor rails** on shunting stages, switches and lift sections for example are usually solved - in this list as well - with transfer caps, larger rail separations with pick-up guides for the ascent and descent of the current collectors.

On the following pages you will find cross-references of other FABA-system components to the various assembly units which should be observed under all circumstances because data on current collectors to be used are stated therein for example.

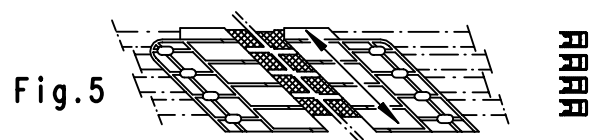
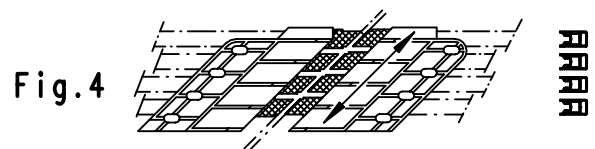
All listed components have been developed from the practice and can in general be obtained from stock.

### CONTENTS

**Conductor-Rail-Transfer, multi-pole**  
with straight caps  
for shifts according to figs. 1, 2 and 3



**Conductor-Rail-Transfer, multi-pole**  
with bevel-cut caps  
for shifts according to figs. 4 and 5



**Conductor-Rail-Transfer, multi-pole**  
with pick-up guides to fig. 6

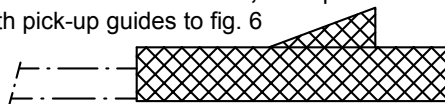


Abb. 6

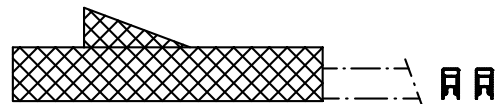
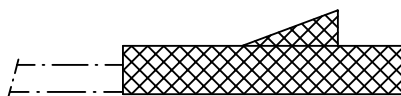


Fig. 6



**FABA – a product of FAHRLEITUNGSBAU GmbH**



### Mechanical Separations For Individual Selection

multi-pole, with straight caps  
max. vertical and horizontal deviation  $\pm 2$  mm  
Requires / collector to bridge

Possibilities of mounting

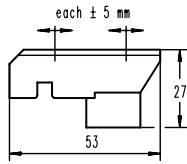


Fig. 1

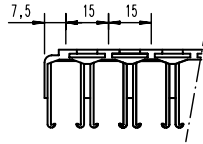


Fig. 2

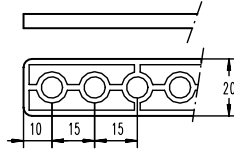


Fig. 3

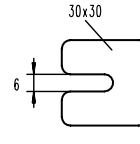


Fig. 4



Fig. 10

Transfer caps

for conductor rails FABA 100  
für conductor rails FABA 30 see IS 100 C page 13

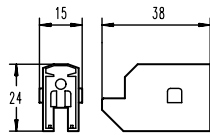


Fig. 5

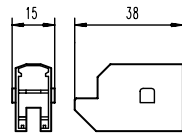


Fig. 6

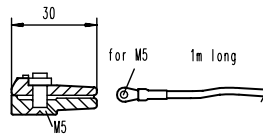


Fig. 8

Fig. 9

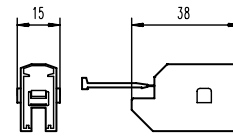


Fig. 7

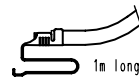


Fig. 11

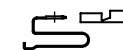


Fig. 12

ass.height 27	Order-No.		poles	Identi- fication	consisting of :	Weight		
	ass.height 32	ass.height 40				H 27	H 32	H 40
241 006 250	241 006 260	241 006 270	4-	Fig.	complete; individual parts in bag;	0,038	0,046	0,050
241 006 251	241 006 261	241 006 271	5-	1 + 2	<b>consisting of :</b>	0,042	0,051	0,057
241 006 252	241 006 262	241 006 272	6-	3 + 4	1 piece girder, fig. 1	0,046	0,056	0,064
241 006 253	241 006 263	241 006 273	7-		1 piece spacer, fig. 2 :	0,050	0,061	0,071
241 006 254	241 006 264	241 006 274	8-		H 27 = without	0,054	0,066	0,078
241 006 255	241 006 265	241 006 275	9-		H 32 = 5 thick	0,058	0,071	0,085
241 006 280	241 006 290	241 006 300	10-	Transfer	H 40 = 13 thick	0,072	0,086	0,102
241 006 281	241 006 291	241 006 301	11-	Unit less	Bolting Fig. 3 for thickness 5-8 mm	0,076	0,091	0,109
241 006 282	241 006 292	241 006 302	12-	caps and	to 9 pol. 2 pieces from 10 pol. 3 pieces	0,080	0,096	0,116
241 006 283	241 006 293	241 006 303	13-	feeds	Each 1 piece plate Fig. 4 (1 and 2 thick)	0,084	0,101	0,123
241 006 284	241 006 294	241 006 304	14-			0,088	0,106	0,130

Order-No.	Fig.	Description			Weight
241 017 045	5	Transfer cap tap on type	Without feed possibility	Plastic black	0,004
241 017 055	6 + 8	Adjustable Transfer cap	With feed clamp	Screw type for cable till max. 2,5 mm <sup>2</sup>	0,025
241 017 152	6 + 8 + 9	Adjustable	2,5 mm <sup>2</sup> Dia -Ø 4,5	1 kV black	Cap, Feed clamp and cable with terminal on end delivered in bag Other lengths on request
241 017 153		Transfer cap with	2,5 mm <sup>2</sup> Dia -Ø 3,9	Ground green/yellow	
241 017 154		1m cable	1,5 mm <sup>2</sup> Dia -Ø 5,1	<b>Data</b> shielded grey	
241 017 175	7 + 10	Adjustable Transfer cap with clip	Clip can be fed if required Clip must be installed with cap	Cap and connecting clip delivered in bag.	0,008
241 017 177	7 + 11	Adjustable	2,5 mm <sup>2</sup> Dia -Ø 4,5	1 kV black	Cap and cable delivered in bag
241 017 178		Transfer cap with	2,5 mm <sup>2</sup> Dia -Ø 3,9	Ground green/yellow	
241 017 179		1m cable	1,5 mm <sup>2</sup> Dia -Ø 5,1	<b>Data</b> grey	

This page contains the combination possibilities for FABA 100 and FABA 30 rails.  
Choose the transfer unit according to the number of poles and the assembly height..  
Then select the cap that fits to the rail system.

For an overview of caps for system FABA 30, see IS 100 C, page 13.

Moniting of the transfer caps for FABA 30 see IS 100 C, page 15; for FABA 100 see IS 100 U, page 5.

### Conductor-Rail-Transfer Complete

multi-pole, with straight caps max.  
vertical and horizontal deviation  $\pm 2$  mm  
Requires 1 collector to bridge

possibilities of mounting

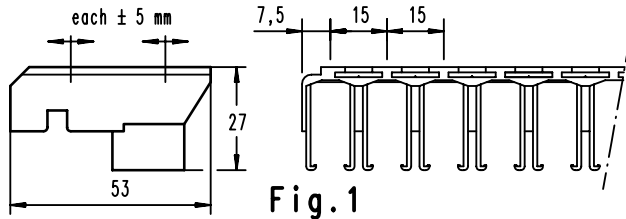
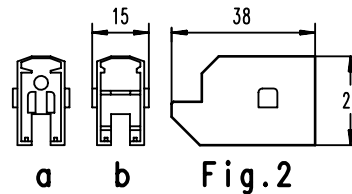


Fig. 1



a b Fig. 2

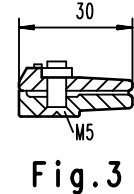


Fig. 3

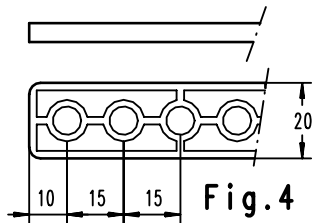


Fig. 4

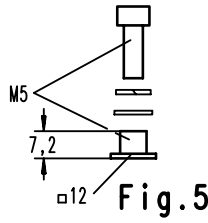


Fig. 5

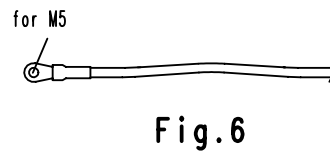


Fig. 6

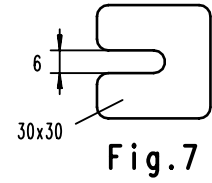


Fig. 7

Order-No.		poles	Identification	Weight			
ass.height 27	ass.height 32	ass.height 40		H 27 H 32 H 40			
241 031 068	241 031 078	241 031 088	4-	complete; individual parts in bag; <b>consisting of :</b> 1 piece girder, fig. 1 .. piece caps, fig. 2a  1 piece spacer, fig. 4 : H 27 = without H 32 = 5 thick H 40 = 13 thick  Bolting, fig. 5 for thickn. 5-8 mm to 9 poles 2 pieces, from 10 poles 3 pieces each 1 piece plate, fig. 7 (1 a. 2 thick)	0,054 0,062 0,066		
241 031 069	241 031 079	241 031 089	5-		0,062 0,071 0,077		
241 031 067	241 031 077	241 031 087	6-		0,070 0,080 0,088		
241 031 066	241 031 076	241 031 086	7-		0,078 0,089 0,099		
241 031 061	241 031 071	241 031 081	8-		0,086 0,098 0,110		
241 031 145	241 031 155	241 031 165	9-		0,094 0,107 0,121		
241 031 140	241 031 150	241 031 160	10-		0,122 0,126 0,142		
241 031 141	241 031 151	241 031 161	11-		0,120 0,135 0,153		
241 031 142	241 031 152	241 031 162	12-		0,128 0,144 0,164		
241 031 143	241 031 153	241 031 163	13-		0,136 0,153 0,175		
241 031 144	241 031 154	241 031 164	14-		0,144 0,162 0,186		
241 031 038	241 031 048	241 031 057	4-		complete; individual parts in bag; <b>consisting of :</b> 1 piece girder, fig. 1 .. piece caps, fig. 2b  .. piece screw-clamps, fig. 3 1 piece spacer, fig. 4 : H 27 = without H 32 = 5 / H 40 = 13 thick  Bolting, fig. 5 for thickn. 5-8 mm to 9 poles 2 pieces, from 10 poles 3 pieces each 1 piece plate, fig. 7 (1 a. 2 thick)	0,138 0,146 0,150	
241 031 039	241 031 049	241 031 058	5-			0,167 0,176 0,182	
241 031 037	241 031 047	241 031 056	6-			0,196 0,206 0,214	
241 031 036	241 031 046	241 031 055	7-	0,225 0,236 0,246			
241 031 031	241 031 041	241 031 050	8-	0,254 0,266 0,278			
241 031 185	241 031 195	241 031 205	9-	0,283 0,296 0,310			
241 031 180	241 031 190	241 031 200	10-	0,322 0,336 0,354			
241 031 181	241 031 191	241 031 201	11-	0,351 0,366 0,384			
241 031 182	241 031 192	241 031 202	12-	0,380 0,396 0,416			
241 031 183	241 031 193	241 031 203	13-	0,403 0,426 0,448			
241 031 184	241 031 194	241 031 204	14-	0,438 0,456 0,480			
241 040 421	Fig. 6	Feed cable	2,5 mm <sup>2</sup> outer- $\varnothing$ 4,5	1 kV black		single-strandet cored; flexible; halogen free; one end with cable lug for M5; (other lengths by request)	0,044
241 040 408		1 m long	2,5 mm <sup>2</sup> outer- $\varnothing$ 3,9	Ground green-yellow			0,036
241 024 052	Fig 7	Shim	each 15 pieces 1 mm and 2 mm thick, for height adjustment			0,042	
241 046 030	not shown	drill template	for even no. of poles; for AMS-track 180 x 60			0,820	
241 046 080			for odd no. of poles; for AMS-track 180 x 60			0,700	
241 017 045	Fig. 2a	Transfer cap	Tap on type			as spare  only	
241 017 035	Fig. 2b		Screw on type for clamp Fig. 3				
251 022 010	Fig. 3	Screw-clamp	with square nut and Philips screw M5				
241 017 055	Fig. 2b And 3	Transfer cap	without cable; orange cap with screwable clamp in bag				
241 013 090			for H 27; M5 x 10				
241 013 091	Fig. 5	Bolting	for H 32; M5 x 14 with nut, washer, spring washer; in bag			0,010 0,012	

### Conductor-Rail-Transfer multi-pole, with straight caps - Continuation -

#### Technical Information

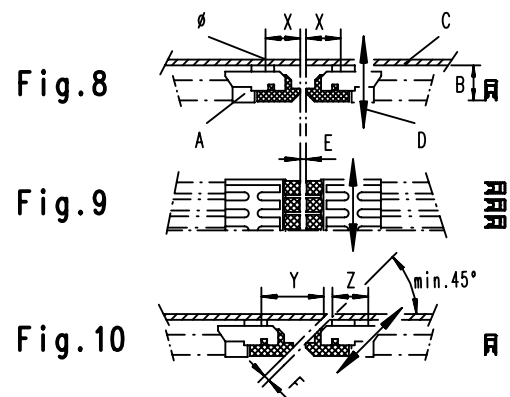
- The permissible displacement of heights and / or sides of two opposing caps is **max.  $\pm 2$  mm** relative to each other.
- The conductor rail center separation is 15 mm.
- Design with "plug-type caps": without feed possibility; caps are not remountable.
- Design with "clip-type caps": with possibility to connect feed cables 1.5 or 2.5 mm<sup>2</sup>.
- Permissible ambient temperatures – 30°C to + 80°C.
- Suitable for traveling speeds up to 300 m/min.
- Position of collector surfaces selectively facing down or sideways.
- The spacer shims, fig. 7, are inserted between the bolting if required, to achieve the correct transfer height from cap to cap.

#### Planning Instructions

- Basically: Prerequisite for the correct functioning of the conductor rail transfers is, that the mechanics, e.g. switch / lift section correctly fulfills the requirements this also with a loaded carrier; particularly the air-gap, the displacement of height- and side at the transfers is to be kept.
- The passage of one of our current collector bridges both metal conductor rails with its collector shoe, hence, only **one current collector** will be required **per rail**.
- The ground conductor rail may be located at an arbitrary point.
- Combinations - plug-type and clip-type caps are possible at the same transfer point or the same holder. If required, please order appropriate parts or submit a corresponding request.
- These transfers arrest the conductor rail in longitudinal direction, Hence, they are "fixed points" with the advantage that the correctly adjusted transfer air-gap remains fixed.
- Only position transfers in the area of the bend if the radius of the conductor rails is at least 750 mm.

#### Installation Instructions

- Drill the monorail web or bracket "C" (possibly use a template); per transfer up to 9 poles = 2 holes, from 10 poles = 3 holes. For dimensions refer to figs. 8 and 10.
- Insert the square nuts into the slots of the girder.
- Insert spacers for assembly heights of 32 and 40.
- Loosely bolt on the holder - without caps.
- Prepare all transfers in this manner.
- Cut the conductor rails - bends also - to exact length; deburr very carefully, on the inside also.
- Install the cap, fig. 2a according to fig 11, with light blows of the hammer.
- Mount cap, fig. 2b according to fig. 12, (perhaps with feed cable):
  - Loosely connect the cable to the screw terminal (fig. 3)
  - Insert the screw terminal into the cap
  - Together push them onto the conductor rail.
  - Loosely tighten the Philips-screw.
- All caps have to absolutely embrace both sides of the conductor rail.
- Clip the conductor rails - with the installed caps - into the holders; both sides of the conductor rail have to be embraced under all circumstances.
- **Carefully line-up the caps** with the **transfer air-gap**: especially the caps corresponding to fig. 12 may be adjusted by 3 mm!
- **Bolt the holder** to the track / traverse.
- **Screw down the caps** (fig. 12), (Philips-screw).
- Check all transfers, also required during the shifting process.
- For unequal heights from cap to cap, fig. 7, insert spacer plates, if required, at the bolting to the track.



- A = conductor rail transfer, complete
- B = assembly height 27 or 32 or 40
- C = AMS-track or other traverse
- D = direction of displacement
- E = fig. 8 and 9 transfer air-gap: max. 5 mm between the caps
- F = fig. 10 transfer air-gap: max. 3 mm between the caps

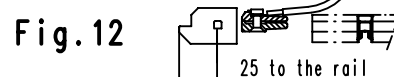
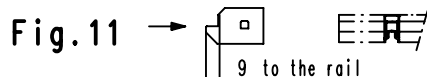
#### Fastening measures:

Fig. 8 and 9 :  $x = 28 \pm 5$  or  $55 \pm 5$  (selectively)

Fig. 10 for 45° displacement:

Assembly height 27 :	$Y = 50 \pm 5;$	$Z = 38 \pm 5$
Assembly height 32 :	$Y = 55 \pm 5;$	$Z = 33 \pm 5$
Assembly height 40 :	$Y = 63 \pm 5;$	$Z = 25 \pm 5$

$\emptyset$ = Bore in "C" :	Assembly height 27=7.2 + 0.3
	Assembly height 32=5.0 + 0.5
	Assembly height 40=5.0 + 0.5

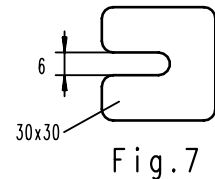
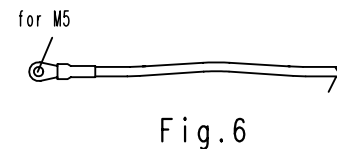
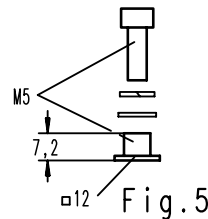
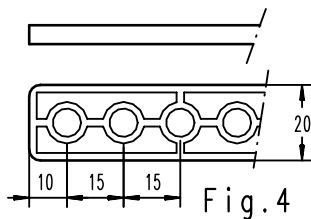
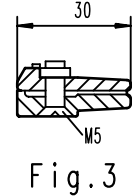
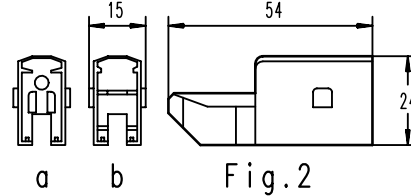
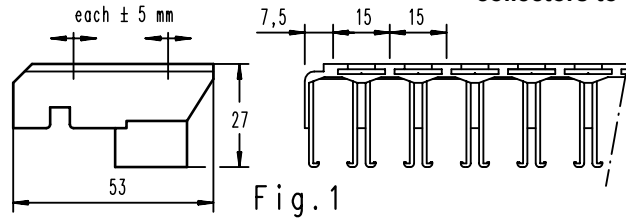


### Conductor-Rail-Transfer

multi-pole, with straight caps

max. vertical and horizontal deviation  $\pm 4$  mm  
Requires 2 collectors to bridge

Possibilities of mounting  
each  $\pm 5$  mm



Order-No.			poles	Identification		Weight			
ass.height 27	ass.height 32	ass.height 40				H 27	H 32	H 40	
241 031 601	241 031 611	241 031 621	4-	Transfer complete	complete; individual parts in bag;	0,058	0,066	0,070	
241 031 602	241 031 612	241 031 622	5-		<b>consisting of :</b>	0,067	0,076	0,082	
241 031 603	241 031 613	241 031 623	6-		1 piece girder, fig. 1	0,076	0,086	0,094	
241 031 604	241 031 614	241 031 624	7-		.. piece caps, fig. 2a	0,085	0,095	0,106	
241 031 551	241 031 561	241 031 571	8-		With tap	1 piece spacer, fig. 4 :	0,094	0,106	0,118
241 031 552	241 031 562	241 031 572	9-		on caps	H 27 = without	0,103	0,116	0,130
241 031 553	241 031 563	241 031 573	10-			H 32 = 5 thick	0,122	0,136	0,152
241 031 554	241 031 564	241 031 574	11-			H 40 = 13 thick	0,131	0,146	0,164
241 031 555	241 031 565	241 031 575	12-			Bolting, fig. 5 for thickn. 5-8 mm to 9	0,140	0,156	0,176
241 031 556	241 031 566	241 031 576	13-			poles 2 pieces, from 10 poles 3 pieces	0,149	0,166	0,188
241 031 557	241 031 567	241 031 577	14-			each 1 piece plate, fig. 7 (1 a. 2 thick)	0,158	0,176	0,200
241 031 631	241 031 641	241 031 650	4-		Transfer complete	complete; individual parts in bag;	0,142	0,150	0,154
241 031 632	241 031 642	241 031 651	5-			<b>consisting of :</b>	0,172	0,181	0,187
241 031 633	241 031 643	241 031 652	6-			1 piece girder, fig. 1	0,202	0,212	0,220
241 031 634	241 031 644	241 031 653	7-	.. piece caps, fig. 2b		0,232	0,243	0,253	
241 031 501	241 031 511	241 031 521	8-	With feed caps	.. piece screw-clamps, fig. 3	0,262	0,274	0,286	
241 031 502	241 031 512	241 031 522	9-		1 piece spacer, fig. 4 :	0,292	0,305	0,319	
241 031 503	241 031 513	241 031 523	10-		H 27 = without	0,332	0,346	0,364	
241 031 504	241 031 514	241 031 524	11-		H 32 = 5 / H 40 = 13 thick	0,362	0,377	0,395	
241 031 505	241 031 515	241 031 525	12-		Bolting, fig. 5 for thickn. 5-8 mm to 9	0,392	0,408	0,428	
241 031 506	241 031 516	241 031 526	13-		poles 2 pieces, from 10 poles 3 pieces	0,416	0,439	0,461	
241 031 507	241 031 517	241 031 527	14-		each 1 piece plate, fig. 7 (1 a. 2 thick)	0,452	0,470	0,494	
241 040 421	Fig. 6	Feed cable	2,5 mm <sup>2</sup> outer- $\varnothing$ 4,5	1 kV black	single-strandet cored; flexible, halogen free;	0,044			
241 040 408		1 m long	2,5 mm <sup>2</sup> outer- $\varnothing$ 3,9	Ground green-yellow					one end with cable lug for M5;
					(other lengths by request)	0,036			
241 024 052	Fig 7	Shim	each 15 pieces 1 mm and 2 mm thick, plastic-orange; in bag					0,042	
241 046 030	Not shown	Drill template	for even no. of poles;		for AMS-track 180 x 60			0,820	
241 046 080			for odd no. of poles;		for AMS-track 180 x 60			0,700	
241 017 048	Fig. 2a	Transfer cap	Tap on type					0,004	
241 017 035	Fig. 2b		Screw on type for clamp Fig.3					0,004	
251 022 010	Fig. 3	Screw-clamp	with square nut and Philips screw M5			<b>as spare</b>		0,021	
241 017 155	Fig. 2b And 3		Transfer cap	without cable;				0,025	
				black cap with screwable clamp in bag					
241 013 090			for H 27; M5 x 10			<b>only</b>		0,010	

241 013 091	Fig. 5	Bolting	for H 32; M5 x 14	with nut, washer, spring washer; in bag		0,012
241 013 092			for H 40; M5 x 22			0,014

### Conductor-Rail-Transfer multi-pole, with straight caps - Continuation -

#### Technical Information

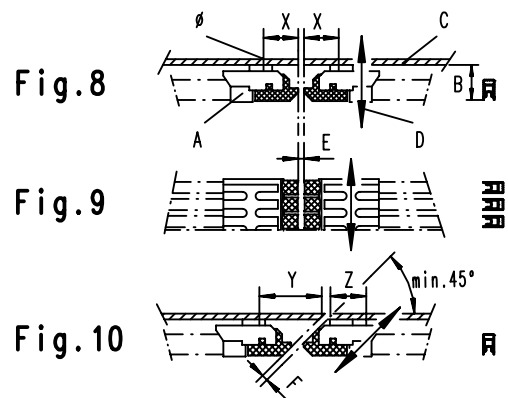
- The permissible vertical and horizontal deviation of two opposing caps is max.  $\pm 4$  mm relative to each other.
- The conductor rail center separation is 15 mm.
- Design with "plug-type caps": without feed possibility; caps are not remountable.
- Design with "clip-type caps": with possibility to connect feed cables 1.5 or 2.5 mm<sup>2</sup>.
- Permissible ambient temperatures – 30°C to + 80°C.
- Suitable for traveling speeds up to 300 m/min.
- Position of collector surfaces down or sideways.
- The shims, fig. 7, are inserted between the bolting if required, to achieve the correct transfer height from cap to cap.

#### Planning Instructions

- Basically: Prerequisite for the correct functioning of the conductor rail transfers is, that the mechanics, e.g. switch / lift section correctly fulfills the requirements this also with a loaded vehicle; particularly the air-gap, the displacement of height- and side at the transfers is to be kept.
- For installations equipped with these transfers the equipment has to be equipped with **two current collectors for each conductor rail** - also ground (exception collectors with double heads).
- The ground conductor rail may be located at an arbitrary point.
- Combinations - plug-type and clip-type caps are possible at the same transfer point or the same girder. If required, please order appropriate parts or submit a corresponding request.
- These transfers fix the conductor rail in longitudinal direction, Hence, they are "fixed points" with the advantage that the correctly adjusted transfer air-gap remains fixed.
- Only position transfers in the area of a bend if the radius of the conductor rails is at least 750 mm.

#### Installation Instructions

- Drill the monorail web or bracket "C" (possibly use a template); per transfer up to 9 poles = 2 holes, from 10 poles = 3 holes. For dimensions refer to figs. 8 and 10.
- Insert the square nuts into the slots of the girder.
- Insert spacers for assembly heights of 32 and 40.
- **Loosely** bolt on the holder - without caps.
- Prepare all transfers in this manner.
- Cut the conductor rails - bends also - to exact length; deburr very carefully, endsot insides also.
- Install the cap, fig. 2a according to fig 11, with light blows of the hammer.
- Mount cap, fig. 2b according to fig. 12, (perhaps with feed cable):
  - Loosely connect the cable to the screw terminal (fig. 3)
  - Insert the screw terminal into the cap
  - Together push them onto the conductor rail.
  - **Loosely** tighten the Philips-screw.
- All caps have to absolutely embrace both sides of the conductor rail.
- Clip the conductor rails - with the installed caps - into the holders; both sides of the conductor rail have to be embraced under all circumstances.
- **Carefully line-up the caps** with the **transfer air-gap**: especially the caps corresponding to fig. 12 may be adjusted by 3 mm!
- **Bolt the holder** to the track / web.
- **Screw down the caps** (fig. 12), (Philips-screw).
- Check all transfer, also required during The shifting process .
- For unequal heights from cap to cap, insert shims, fig. 7, if required, at the bolting to the track.



- A = conductor rail transfer, complete  
 B = assembly height 27 or 32 or 40  
 C = AMS-track or other traverse  
 D = direction of displacement  
 E = fig. 8 and 9 transfer air-gap:  
 min. 2 mm, max. 8 mm between the caps  
 F = fig. 10 transfer air-gap:  
 max. 3 mm between the caps

#### Fastening measures:

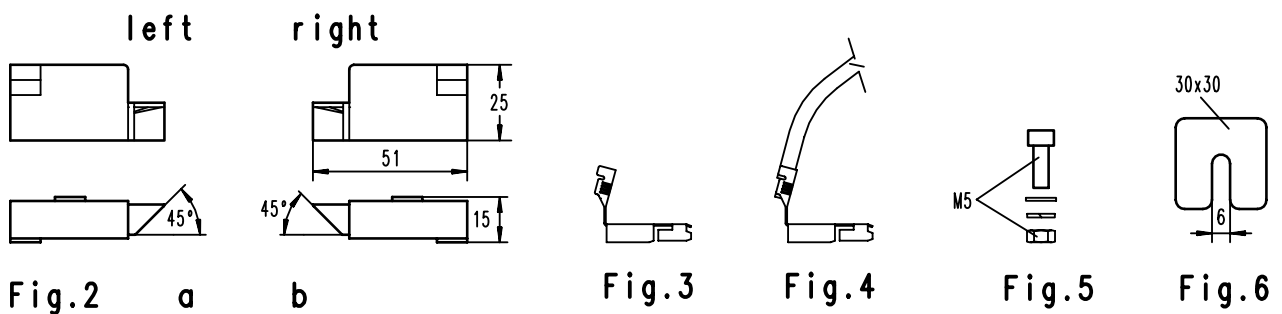
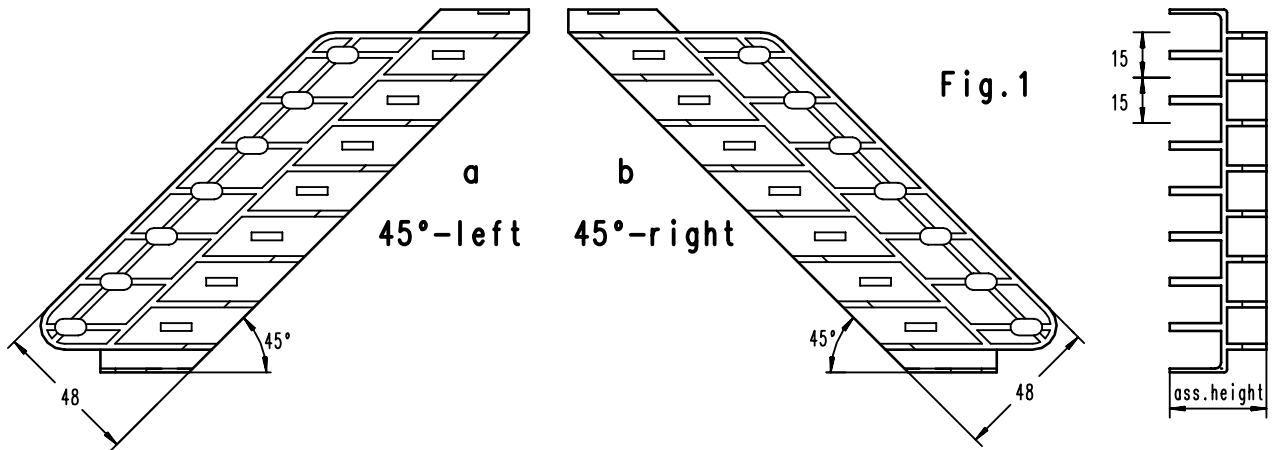
Fig. 8 and 9 :  $x = 44 \pm 5$  or  $55 \pm 5$  (selectively)  
 Fig. 10 for 45° displacement :

Assembly height 27 :  $Y = 68 \pm 5$ ;  $Z = 54 \pm 5$   
 Assembly height 32 :  $Y = 73 \pm 5$ ;  $Z = 49 \pm 5$   
 Assembly height 40 :  $Y = 81 \pm 5$ ;  $Z = 41 \pm 5$

$\emptyset$  = Bore in "C" : Assembly height 27=7.2 + 0.3  
 Assembly height 32=5.0 + 0.5  
 Assembly height 40=5.0 + 0.5

### Conductor Rail Transfer For conductor rails facing downwards

multi-pole, 45°



Order-No.		poles	Identification		Weight			
ass.height32	ass.height40				AH 32	AH 40		
241 031 465	241 031 461	4-	Transfer 45° - left	Complete; individual parts in bag; <b>Consisting of:</b> 1 piece girder, fig. 1a; .. piece caps, fig. 2a; .. piece plug, fig. 3;	0,084	0,086		
241 031 463	241 031 459	5-			0,092	0,094		
241 031 334	241 031 338	6-			0,100	0,102		
241 031 360	241 031 457	7-			0,108	0,110		
241 031 332	241 031 330	8-			0,116	0,118		
241 031 395	241 031 391	4-			Transfer 45° - right	Complete; individual parts in bag; <b>consisting of:</b> 1 piece girder, fig. 1b; .. piece caps, fig. 2b; .. piece plug, fig. 3;	0,084	0,086
241 031 393	241 031 389	5-					0,092	0,094
241 031 344	241 031 348	6-					0,100	0,102
241 031 350	241 031 387	7-	0,108	0,110				
241 031 342	241 031 340	8-	0,116	0,118				
241 040 492	241 040 491	Fig. 4	Feed cable 1 m long	2,5 mm <sup>2</sup> outer-∅ 4,5 2,5 mm <sup>2</sup> outer-∅ 4,0			1 kV black <b>Ground</b> green- yellow	single-core; highly flexible; ne side with plug; (other lengths by request)
241 024 052	Fig. 6	Shim	each 15 pieces, 1 mm and 2 mm thick, plastic-orange; in bag			0,042		
241 017 070	Fig. 2a	Cap - left	plastic-orange; fitting plug, fig. 3		<i>for spare only</i>	0,005		
241 017 065	Fig. 2b	Cap - right	plastic-orange; fitting plug, fig. 3		<i>for spare only</i>	0,005		
241 026 020	Fig. 3	Plug	bronze; for cross-sections 1.5 and 2.5 mm <sup>2</sup>		<i>for spare only</i>	0,003		
241 013 096	Fig. 5	Bolting	for AH 32 mm	M5 x 20	with nut, washer, spring washer; in bag	<i>for spare only</i>	0,007	
241 013 097			for AH 40 mm	M5 x 30				0,008

### Conductor Rail Transfer multi-pole, 45° - Continuation -

#### Technical Information

- The permissible vertical and horizontal deviation of two opposing caps is max.  $\pm 2$  mm relative to each other.
- The incline of the transfer lies at **45° to the line of the conductor rail**. Other inclines by request.
- The conductor rail center separation is 15 mm.
- One plug belongs to each cap; it is discarded if a connecting cable is used.
- Permissible ambient temperatures  $-30$  °C to  $+80$  °C.
- Suitable for traveling speeds up to 200 m/min.
- Position of collector surfaces down or sideways.
- Assembly height 27 and design of more than 8 poles by request.
- The Shimes, fig. 6, are inserted between the bolting if required, to achieve the correct transfer height from cap to cap.

#### Planning Instructions

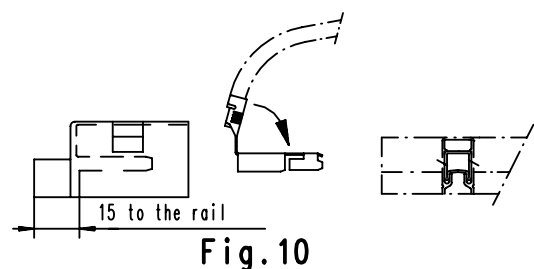
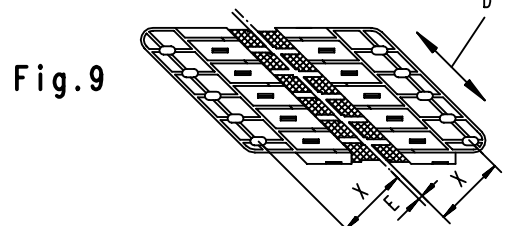
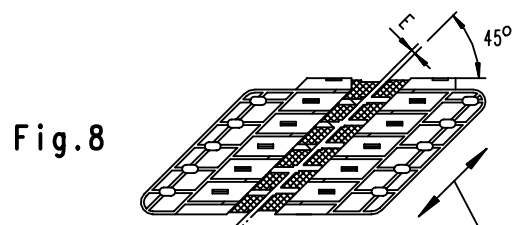
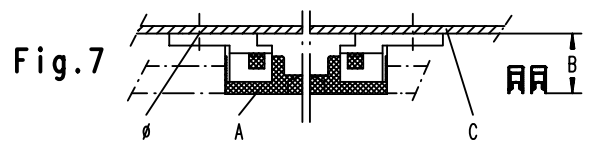
- Basically: Prerequisite for the correct functioning of the conductor rail transfers is, that the mechanics, e.g. switch / lift section correctly fulfils the requirements this also with a loaded carrier; particularly the air-gap, the displacement of height- and side at the transfers is to be kept.
- On passage of one of our current collectors, the collector shoe bridges both metal conductor rails, hence, **only one current collector** will be generally required.
- The ground conductor rail may be located at an arbitrary point.
- These transfers fix the conductor rail in longitudinal direction, Hence, they are "fixed points" with the advantage that the correctly adjusted transfer air-gap remains fixed.
- Only position transfers in the area of a bend if the radius of the conductor rails is at least 750 mm.

#### Installation Instructions

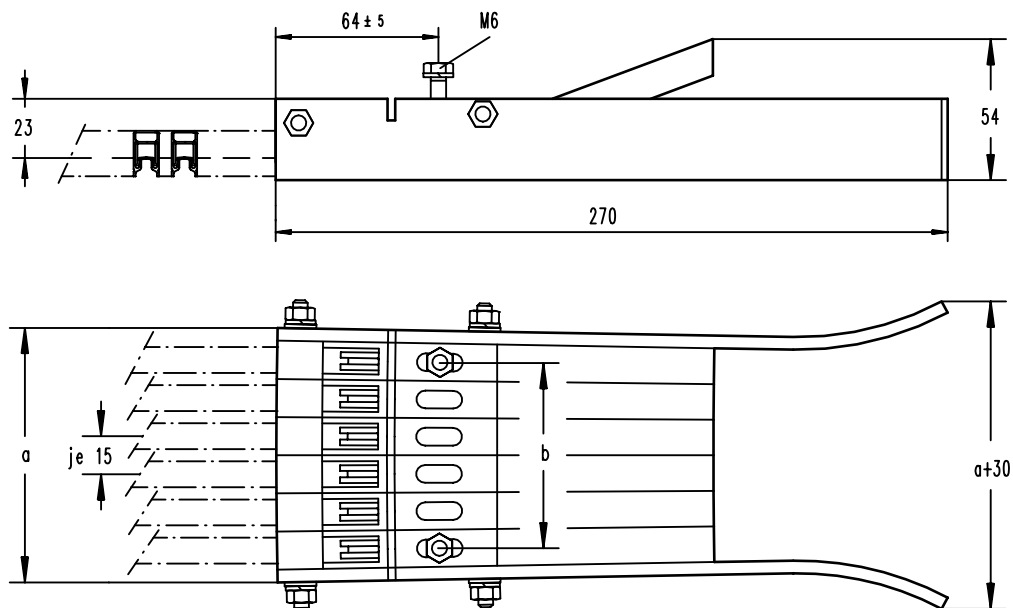
- Drill web or beam "C".
- **Loosely** bolt down the holder.
- Prepare all transfers.
- Cut conductor rails - bends also - to exact length; deburr carefully also the inside.
- Install the cap according to fig. 10 (with or without cable):
  - plug into the end of the rail until positive stop
  - bend the end of the plug - refer to arrow
  - push on cap until positive stop.
- All caps to embrace both sides of the conductor under all circumstances.
- **Clip** the conductor rails - with the installed caps - **into the holders**.
- **Carefully line-up the caps** with the **transfer air-gap**.
- **Bolt the holder** to the track / web.
- Check all transfer, also required during the shifting process .
- For unequal heights from cap to cap, insert shimes, fig. 6, if required.

A = conductor rail transfer, complete  
 B = assembly height 32 or 40  
 C = AMS-track or other traverse  
 D = direction of displacement  
 E = transfer air-gap max. 3 mm between the caps

Fastening measure:  $x = 48 \pm 3$  mm  
 $\varnothing =$  bore in "C" =  $5,5 + 0,5$  mm



### Conductor-Rail-Separations pick-up guide for current collectors



Order-No.	Identification		Dim. a	Dim. b = mounting		weight
241 030 025		1-poles	25	-		0,150
241 030 030		2-poles	40	15	completely premounted;	0,250
241 030 035		3-poles	55	30		0,300
241 030 040		4-poles	70	45		0,350
241 030 045		5-poles	85	60		0,400
241 030 050		6-poles	100	75	completely premounted;	0,450
241 030 055	Pick-up guide	7-poles	115	90		0,500
241 030 056		8-poles	130	105	plastic-orange;	0,550
241 030 057		9-poles	145	120		0,600
241 030 058		10-poles	160	135	(other number of poles by request)	0,650

### Technical Information

- Suitable for installations which operate with current collectors (all types).
- The conductor rail center separation is **15 mm**.
- Suitable for collector surfaces facing down or sideways;
- for a back and forth operation.
- The conductor bar connecting point to the pick up must be without electrical current as the air gap ionization will cause sparking problems, a rail with a separation piece should be connected then a feed.
- Traveling speed of max. 100 m/min.
- The ends of the conductor cannot be fed. Feeds must be located further back.
- Permissible ambient temperatures – 30°C bis + 50°C, i.e. here is a restriction as compared with the remaining list.
- Chemical resistivity as for remaining list.
- The pick-up guide is not remountable, i.e. it cannot be mounted several times over.

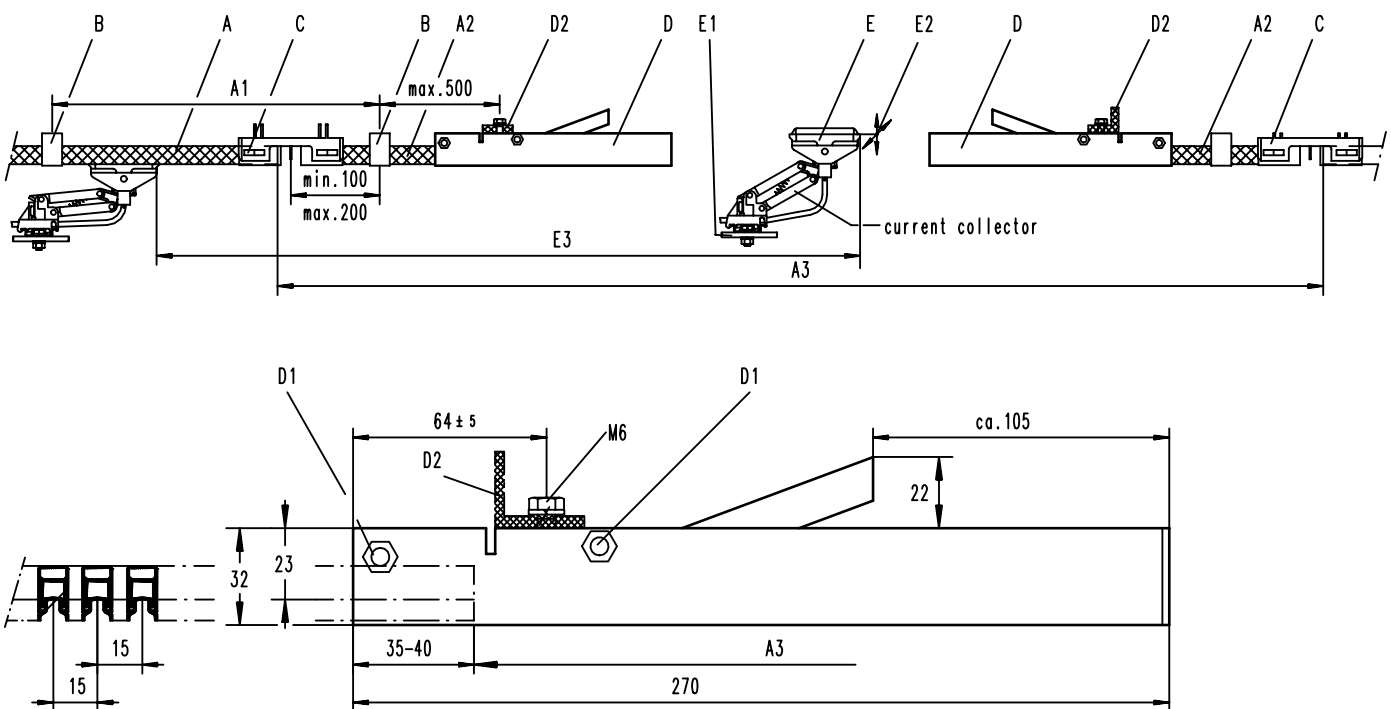
### Planning Instructions

- Pick-up guides are required for larger conductor rail interruptions and serve the ascent- and descent of the current collectors.
- To assure a continuous supply of power - or data transfer - at least two current collectors are to be located on each mobile carrier at the appropriate distance for each conductor rail - also ground - for bridging.
- The current collector or the live collector shoes have to be protected against contact in the area of the interruption by confinements or covers.
- The mobile equipment has to be guided precisely in the area of interruption, so that the current collector - **set does not deviate more than ± 7mm when entering the funnel**.
- The ground conductor rail may be located at an arbitrary point.



- The funnel secures the conductor rails in longitudinal direction, hence, it is a valid "fixed point".

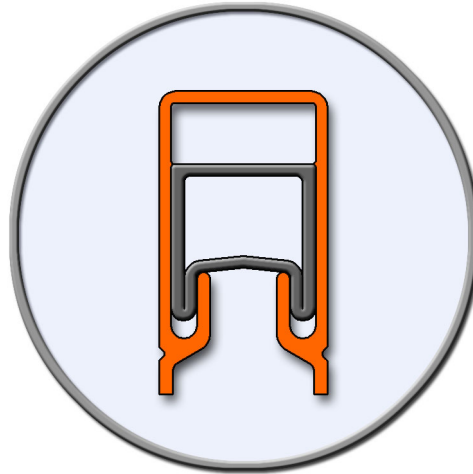
### Conductor-Rail-Separations pick-up guide for current collectors - Continuation -



- A = Conductor rail  
 A<sub>1</sub> = Spacing of the conductor rail hangers : in straight sections max. 800 mm, in bends max. 400 mm.  
 A<sub>2</sub> = Conductor rail sections for simplified installation : length, approx. 0,5 m .  
 A<sub>3</sub> = Gap section between the metal conductor rails; length, corresponding to installation.
- B = Hanger clamp : one- or multi-pole; assembly height, corresponding to installation.  
 C = Separation with continuous flange must have the same height as the hanger clamp.
- D = Pick-up guide, multi-pole : suitable for all one-arm current collectors.  
 D<sub>1</sub> = Pick-up guide cross-bolts : refer to installation instructions.  
 D<sub>2</sub> = Console for funnel : thickness, max. 8 mm; also refer to measurement "b" in the table,  
 up to 6 poles = 2 M6 bolts, more than 7 poles = 3 M6 bolts.
- E = One-arm current collector : operative pulling or pushing.  
 E<sub>1</sub> = Console for current collector : mounted to the carrier.  
 E<sub>2</sub> = **Deviations of current collector : max. ± 7 mm** = to all sides, preceding the move into the pick-up guide.  
 E<sub>3</sub> = Separation of collector shoes : must be larger than the gap section "A3".

### Installation Instructions

- Cut the conductor rail sections "A2" to lengths of approx. 1 m; deburr carefully - also the contact surface.
- Insert the rail section into the pick-up guide piece 35 – 40 mm - tap with light blows against the exposed end of the conductor rail.
- After reassembling tighten the cross-bolts "D1" of the pick-up guide.
- Lift up the pick-up guide with the conductor rail section; clip the conductor rails into the support clamps, align the pick-up guide and bolt it down.
- Inspection: Do all current collectors move correctly into the pick-up guide?  
 For the current collector attention must be paid that the connecting cable is installed in such a manner as to allow the collector shoe to line up with the conductor rail after exiting the pick-up guide, i.e. does not slant abnormally.



## Conductor Rail System FABA 100

for mobile equipment

### Introduction

Our customers' demands regarding **rail systems** – in particular, electric monorail systems – **with FABA conductor rails already pre-assembled in the factory** have recently increased. Therefore, the installation of the conductor rails on the spot is practically no longer required.

Thus, our newly developed and internationally patented system now enables our customers to install the FABA 100 system directly in the factory to the supporting and running rails of the rail system – e.g. the electric monorail system - and to ship it in this way.

Therefore, the usual assembly work for the conductor rail system to be realised by experts on the spot will be no longer necessary.

However, at the rail splice, the connectors for the conductor rails will still have to be installed. This new development is, however, of such a simple design that even untrained personnel will be able to carry out the installation.

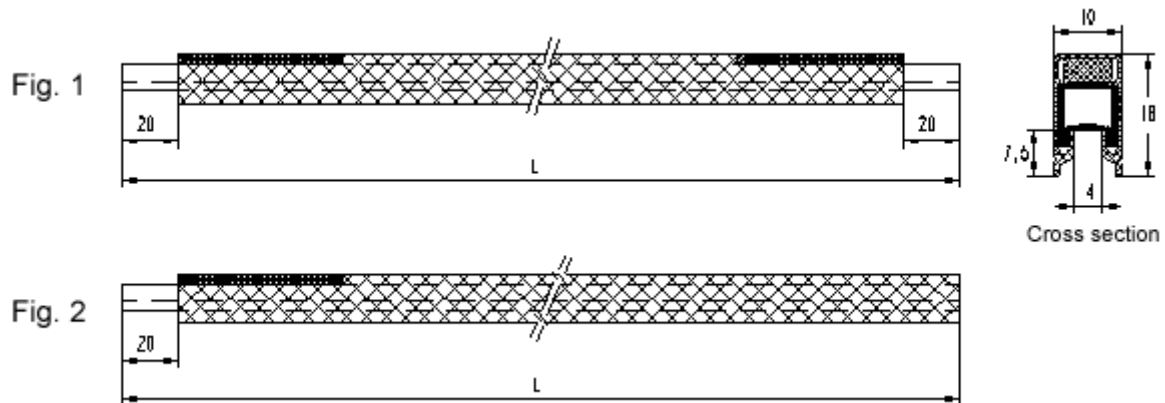
**This new development** will also enable you to reconsider the fabrication, the shipment and the „assembly on the spot“ of your rail system. Frequently, the immediate results will be considerable economical advantages of which you may benefit by using our FABA 100 conductor rail system including its new developments.

If an additional or a completely different component is required for your special rail system which is not part of our standard component list, please, do not hesitate to contact us. Together, we will of course find the best solution for your rail system.

*Our expert field agents are looking forward to making their services available to you.*

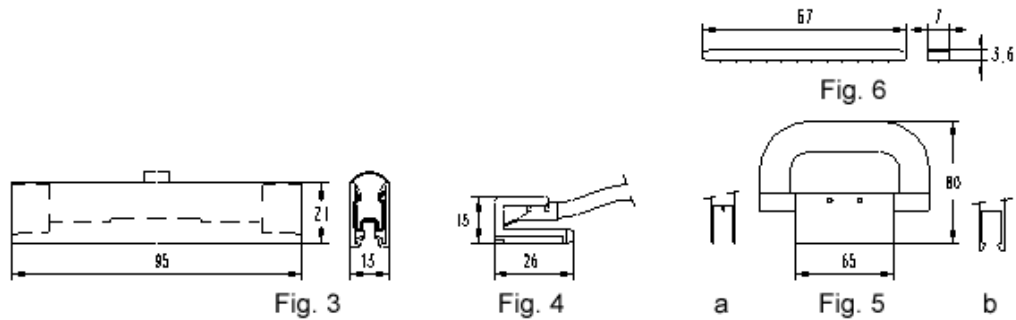
## FABA – a product of FAHRLEITUNGSBAU GmbH

### Conductor rail



Order No.		Identification	Conductor rails Length "L" (other lengths on request)	for monorail/track Length	Insulation	Weight		
200 009 096	Fig. 1	Conductor rail <b>FABA 100</b>	964	1000	Standard – orange, conductor rail Cu	0.260		
200 009 196			1964	2000		0.530		
200 009 296			2964	3000		0.800		
200 009 396			3964	4000		1.070		
200 009 496			4964	5000	1.340			
200 010 096			964	1000	each	0.260		
200 010 196			1964	2000	± 2 mm	0.530		
200 010 296			2964	3000		0.800		
200 010 396			3964	4000		1.070		
200 010 496			4964	5000		1.340		
200 011 096			Fig. 2	Conductor rail <b>FABA 100</b>	964	1000	Halogenfree – orange, conductor rail Cu Imprint HL on insulation	0.260
200 011 196					1964	2000		0.530
200 011 296					2964	3000		0.800
200 011 396					3964	4000		1.070
200 011 496					4964	5000	1.340	
200 012 096					964	1000		0.260
200 012 196	1964	2000				0.530		
200 012 296	2964	3000			Halogenfree – <b>Green</b> , yellow with green stripe	0.800		
200 012 396	3964	4000			Imprint HL on insulation	1.070		
200 012 496	4964	5000				1.340		
200 009 100	Fig. 2	Conductor rail <b>FABA 100</b>			1000		Standard – orange, conductor rail Cu	0.270
200 009 150					1500			0.405
200 009 200					2000			0.540
200 009 250					2500			0.675
200 009 300					3000		0.810	
200 010 100					1000			0.270
200 010 150			1500			0.405		
200 010 200			2000		Standard – <b>Ground</b> , yellow with green stripe	0.540		
200 010 250			2500			0.675		
200 010 300			3000			0.810		
200 011 100			1000		Halogenfree – orange, conductor rail Cu Imprint HL on insulation	0.270		
200 011 150			1500			0.405		
200 011 200			2000			0.540		
200 011 250			2500			0.675		
200 011 300			3000		0.810			
200 012 100			1000			0.270		
200 012 150	1500			0.405				
200 012 200	2000		Halogenfree – <b>Ground</b> , yellow with green stripe	0.540				
200 012 250	2500		Imprint HL on insulation	0.675				
200 012 300	3000			0.810				

### Conductor rail – Continuation –

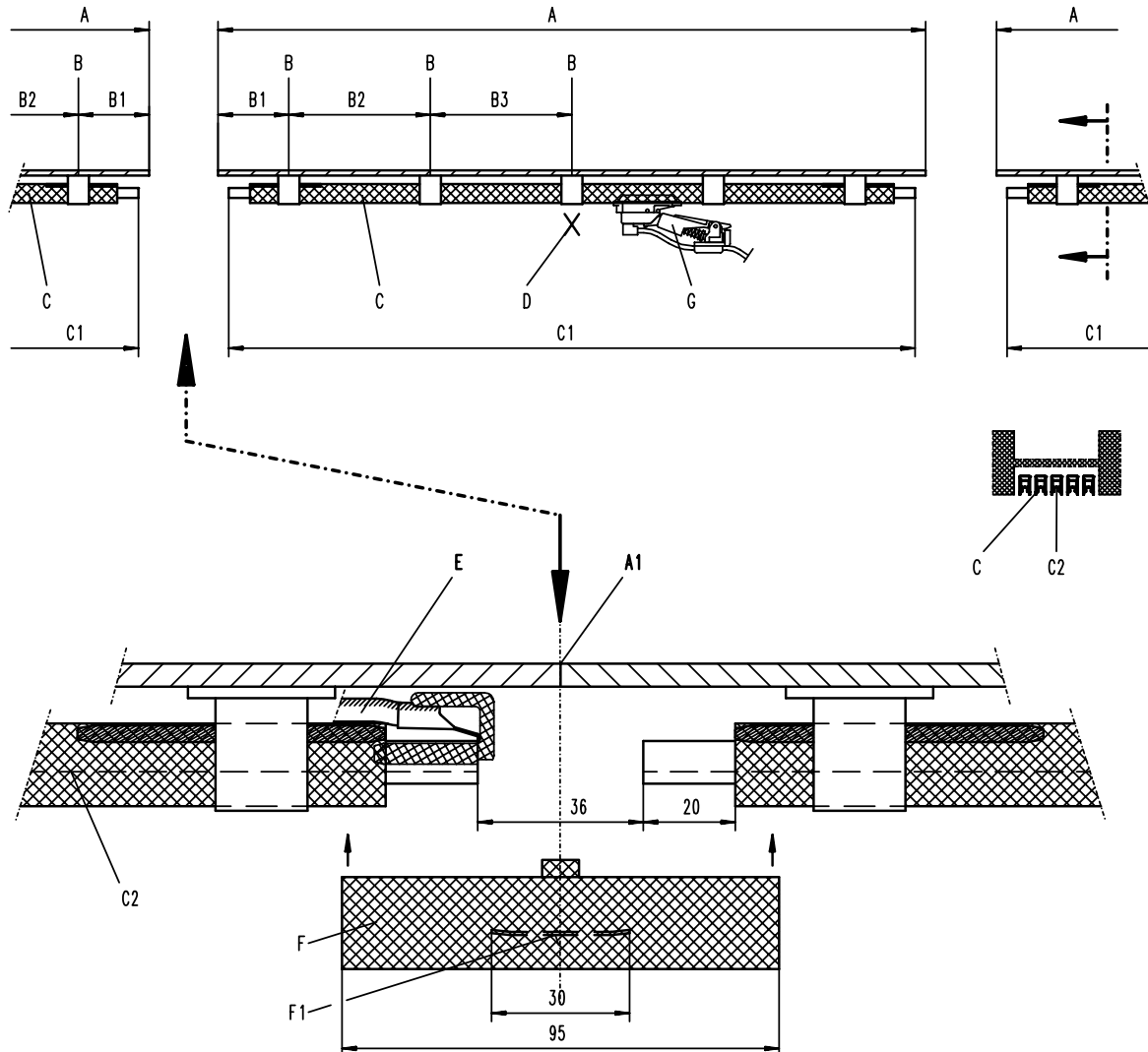


Order-No.	Fig.	Identification				Weight
241 002 015	3	Connector with spacers	one-pole; complete: Bronze clip with insulating black cover and spacers			0.022
241 000 060	6	Distance profile	one-pole; plastic black (only as spare)			0.002
241 015 081	4	Head-power feed for AH from 32 mm cable 1 m long	2.5 mm <sup>2</sup> outer-∅ 4.5	1 kV black	single-core; halogenfree,	0.046
241 015 085			4.0 mm <sup>2</sup> outer-∅ 5.3	1 kV black	flexible;	0.078
241 015 083			6.0 mm <sup>2</sup> outer-∅ 6.5	1 kV black	complete;	0.112
241 015 082			2.5 mm <sup>2</sup> outer-∅ 3.9	<b>Ground</b> green-yellow	one-side with	0.039
241 015 086			4.0 mm <sup>2</sup> outer-∅ 4.9	<b>Ground</b> green-yellow	insulating sleeve and plug;	0.048
241 015 084			6.0 mm <sup>2</sup> outer-∅ 6.3	<b>Ground</b> green-yellow	other lengths on request.	0.072
241 046 085	5a	Assembly tool	smooth jaws	plastic;	for connectors fig. 3	0.130
241 046 086	5b	Dismantling tool	barbed jaws	plastic;	for connectors fig. 3	0.130

### Technical information

- a) Conductor rails FABA 100 with Cu metal rail: ... basically identical to the information of list IS 100 B.
- Permissible continuous current (at 100 % Duty cycle): 100 A, for standard insulation up to an ambient temperature of 35 °C, for halogenfree insulation up to an ambient temperature of 55 °C for higher ambient temperatures, reduction acc. to table 1 of IS 100 A
  - Permissible continuous ambient temperatures - 30 °C up to + 55 °C for standard insulation, - 30 °C up to + 80 °C for halogenfree insulation
  - Resistance of the conductor rails for different ambient temperatures, see table 2 of list 2 Liste IS 100 A
  - Conductor rail acc. to fig. 1; the insulating sleeve is shortened on both ends: to be used for linear rail sections of a length of up to 5 m, if the length tolerance is not larger than ± 2 mm. The conductor rails are 36 mm shorter than the running rail.
  - Conductor rail acc. to fig. 2, the insulating sleeve is shortened on one side: To be used for linear rail sections and for bends, if the length tolerance is not larger than ± 2 mm or for sections longer than 5 m. They may be adapted to each running rail length by shortening (as for the standard conductor rails) or after bending. These rails are connected by a screw connector according to list IS 100 B. For rail lengths longer than 6 m, standard conductor rails according to list IS 100 B will have to be additionally planned. The distance profile is inserted in the upper hollow zone due to stability reasons
  - The installation of the conductor surface is effected either down or sideways
  - The conductor rails are mounted to the supporting/running rails in the factory
- b) Connectors of fig. 3:
- At the rail splice, an air gap of approx. 36 mm will form between the conductor rails. This air gap will be bridged both electrically and mechanically by clipping on the connector (on the spot).
  - Permissible continuous current: 100 A (at 100 % DC)
  - Permissible ambient temperatures: - 30 °C up to + 80 °C
  - Changes of length or expansions of the conductor rails will be compensated for.
  - Regarding the protection against accidental contact: The connector will be installed from the conductor surface side and will form there and also laterally the protection against accidental contact IP 2 x. At the back side, however, the connector is „open“ but only if the installation of the conductor rail system is realised in such a way that the supporting/running rail prevents an accidental contact of the connector.
- c) Head power feed of fig. 4: The power feed for the conductor rails can be effected at every rail splice on one or both sides from an assembly height of 32 mm on.
- d) Tools of fig.5: To facilitate the assembly/disassembly of the connector of fig. 3 (to be carried out on the spot)

### Diagram



- A = **Supporting/ running rail: individual length will be completed in the factory with FABA 100**  
 A<sub>1</sub> = Connecting joint layout: on monorail or track beam
- B = One or multiple-pole hanger clamps  
 B<sub>1</sub> = Distance to end of track section: 70 up to 100 mm  
 B<sub>2</sub> = Hanger distance: for linear sections: max. 800 mm, in bends: max. 400 mm
- C = Conductor rail: acc. to this list, with insulating sleeve shortened at the splice and inserted spacer profile  
 C<sub>1</sub> = Length of the conductor rail: 36 mm shorter than the supporting/running rail  
 C<sub>2</sub> = Conductor surface
- D = Fixed point acc. to list IS 100 B; installation approx. in the centre of each supporting/running rail
- E = Head power feed: acc. to this list, feeding in factory or at the installation location
- F = **Connectors:** acc. to this list;  
**Assembly on the spot:** for the electrical and mechanical connection of the conductor rails  
 F<sub>1</sub> = Metal conductor surface of the connector
- G = Current collector

### Planning instructions

1. **IN THE FACTORY** all individual lengths of the supporting/running rail – both linear sections and bends – are entirely assembled with FABA 100:
  - a) For linear rail section of up to 5 m, the conductor rails acc. to fig. 1 with a shortened insulating sleeve on both sides will have to be planned, the supporting/running rail tolerance, however, must not exceed  $\pm 2$  mm
  - b) For rail sections longer than 5 m, or if the tolerance is larger than  $\pm 2$  mm, conductor rails with a shortened insulating sleeve on only one side will have to be planned acc. to fig. 2. They are to be connected by the standard rail splice connector within the supporting/running rail length, possibly, with the standard conductor rails acc. to list IS 100 B between them. The conductor rail has to spring back by  $18 \pm 2$  mm at the ends of the running rails.
  - c) For bends, in particular, the conductor rails have to be exactly adjusted. In this case, both the standard conductor rails with equally shortened insulating sleeve and also those with an insulating sleeve shortened on only one side may be used, important is that:
    - the supporting/running rails have to have a straight end of at least 100 mm
    - the end of the conductor rail at the supporting/running rail splice must be straight for min. 100 mm
    - the conductor rail will spring back by  $18 \pm 2$  mm to the running rail end
    - The insulating sleeve at the running rail end has to spring back (shortened) by 20 mm regarding the metal conductor rail and that the distance profile is inserted into the upper hollow zone
  - d) All conductor rails have to be arrested approx. in the center of each individual supporting/running rail by means of fixing point clips. This also applies to bends. The fastening devices remain in the conductor rails also at the location of assembly. They are used as transport locks and ensure the expansion or contraction of the conductor rails during their later operation when the ambient temperatures change. Therefore, expansion bridges or expansion rails are not required – unless, there are expansion gaps in the area of the supporting/monorail tracks.
  - e) For control tasks, electrical separations of the conductor rails are possible practically at every point by means of the standard components.
  - f) At the conductor rail splice – i.e. in the area of the supporting/monorail rail splice – the head power feed may be planned on one or on both sides from an assembly height of 32 on acc. to fig 4. We recommend to carry out the assembly in the factory.  
Note: The standard power feeds within the conductor rail lengths may of course also be planned.
  - g) The supporting/running rails for the switch zone are to be equipped by FABA-transfer devices acc. to the specific requirements in the factory, see special list IS 100 B "Transfer Caps" and IS 100 "Separations"
2. The supporting/running rails will then be shipped in this way. At the assembly location, the installation will be realised as usual, however, it must be ensured that the conductor rail system is not damaged neither during the transport nor during the assembly.
3. **AT THE ASSEMBLY LOCATION** only one-pole connectors acc. to fig. 3 are to be clipped on the rail splice either from the front or from the conductor surface – it is always the accessible side. This kind of work can of course be carried out by untrained personnel. To simplify the procedure and also regarding a possible disassembly, simple hand tools are available.

### Installation instructions

1. Conductor rail:
  - a) Hanger distance: for linear sections max. 800 mm, in bends max. 400 mm.
  - b) Shorten- By a fine-toothed hack saw from the conductor surface. De-burr the cut edges thoroughly by a fine file and insert the distance profile into the upper hollow zone.
    - Rail fig. 2: Shorten the end only at which metal rail and insulating sleeve terminate.
    - Rail fig. 1: In general not required, if it is, however, necessary: displace insulating sleeve until it terminates with the metal rail. Shorten this end and push back the insulating sleeve by 20 mm and insert distance profile.
  - c) Bends (also see IS 100 B = conductor rails):
    - Smallest bending radius to all sides: 500 mm.
    - Fabrication by bending machine or bending profile, in general „on the spot“ or by the customer, on request to be supplied by Fahrleitungsbau.
    - Both ends of the conductor rail cannot be bent, approx. 150 mm will remain straight.
    - If two rail bends are attached to one another within a supporting/running rail – thus, conductor rails acc. to fig. 2 – then, shorten the ends to be connected by the linear section of approx. 150 mm. Use screw rail connectors for such a connection only.
2. Connectors fig. 3:
  - Assembly on the spot
  - From the accessible side – thus, install the connector in the centre of the conductor rails from the conductor surface
  - Press on the connector by means of the assembly tool of fig. 5a
  - Check, if the conductor surfaces are exactly aligned
  - The connector is remountable (reusable): For the disassembly, use the tool acc. to fig. 5b
3. Head power feed for assembly heights larger than 32 mm, fig. 4:
  - In general, the assembly is effected in the factory before the connector is mounted
  - Press it completely with the insulating sleeve into the conductor rail end (use a hammer)
  - Ensure a sufficient distance between the metal parts of the supporting/running rail (min. 3 mm)
  - Ensure that the thermal expansion of the conductor rail is not obstructed.





# Maintenance Manual FABA 100

*The insulated conductor rail system FABA 100 requires only little maintenance to ensure its correct functioning and operation safety.*

The regular maintenance intervals will depend on the ambient conditions and have to be defined by the user of the system.  
**FABA recommends at least an annual maintenance procedure!**

The following maintenance work has to be carried out in regular intervals:

## 1. Insulated conductor rail system

### 1.1 Visual inspection

- Check the insulation regarding mechanical damages, contaminations and burns.
- Check the conductor rails regarding oxidations and burns
- Verify, if the rail splice connector is in the correct position.
- Verify, if the power feeds and caps are tightly fixed.
- Damages and contaminations of the hanger clamps.
- Damages and contaminations of the insulating housings.
- Inspection of the connecting cables of the current collectors and of the conductor rails.

### 1.2 Realisation

- Replace all damaged components.
- Tighten all screw connections.
- Clean all oxidised conductor rails by means of FABA cleaning shoes until they are metallicly bright.  
Usually, approx. 20 brushings will be sufficient.  
Afterwards, clean rails with a vacuum cleaner.
- Replace burned or damaged conductor rails.
  
- Clean contaminated insulating components with a vacuum cleaner or remove stains by means of a cleaning cloth.  
Do not use any solvents!

### 1.3 Electrical inspection

- Measurement of the insulating resistance according to the current regulations.

## 2. Current collectors

### 2.1 Visual inspection

- Verify the movability of the pressure spring, of the pivot bearings and of all mechanical articulations.
- Inspection regarding mechanical damages.
- Overheating of the sliding contact due to an excessive transfer resistance.
- Check, if the current collector base plate is damaged and if it is tightly fixed.
- Verify, if the sliding contacts are worn.
- Check the safe function of the plug connection of the connecting cables.
- Check the correct conduct and fastening of the connecting cables.

### 2.2 Realisation

- Replace all worn sliding contacts.
- Replace all worn components.
- Remove all contaminated current collectors and clean them in soap water, remount them when dry. Then, check all movable components regarding their correct operation and soft running.

### 2.3 Mechanical inspection

- Remove the current collector from the contact rail by means of a spring balance and measure the contact pressure shortly before the re-assembly.  
The contact pressure of the parallel-arm current collector should be approx. 6 N.

### 2.4 Electrical inspection

- Measurement of the insulating resistance according to the current regulations.

## 3. Performance check

- After each maintenance procedure, a performance check has to be carried out!
- The current collectors must run on the contact rail without any vibrations.
- A sparking at the sliding contact should not occur.  
A sparking indicates a burned, contaminated or oxidised contact rail.

### Cleaning instructions for FABA 100 conductor rails

Experience has shown that the FABA 100 system is very easy to maintain. In case of considerable contaminations – depending on the ambient conditions at the location of use – a cleaning of the conductor rails is possible as follows:

Mix the cleaning solution (Bioclean) in proportion to 3 : 1 (3 portions of water, 1 portion of cleaning agent). The cleaning agent is not harmful to the environment and neutral to plastic material and to metals.

Clean the conductor rails with a moistened (cleaning agent) cleaning cloth. Clean the cloth in clear water before you use it again. For a better handling, wrap the cloth around a spatula (approx. 150 x 30 / 1 mm). Wear protective gloves to avoid a drying-out of the skin.

After the cleaning procedure with the cleaning agent, clean the conductor rail once again, but this time only by means of a cleaning cloth moistened by clear water. Change the water frequently for both cleaning procedures.

The cleaned conductor surface is finally to be brushed by the cleaning shoes until the conductor surface is metallically bright. A possible oxide film will be eliminated by this cleaning procedure. The cleaning shoes will be removed afterwards.

**Important: Wear protective gloves during all cleaning procedures!**

Our trained maintenance and cleaning personnel will of course make their services available to you as well. We would be glad to submit a corresponding offer.



## Conductor Rail System FABA 100

for mobile equipment

The following components are no longer part of our

**FABA 40**

**FABA 80**

**FABA 100**

### conductor rail programme,

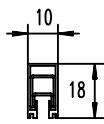
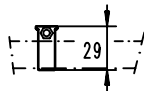
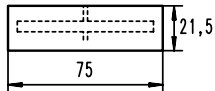
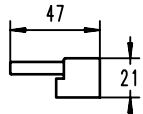
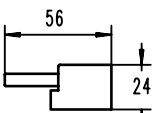
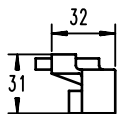
because they either no longer meet the current requirements or they are technically modified or replaced by new components.

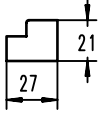
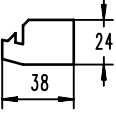
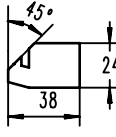
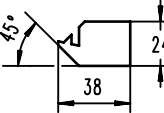
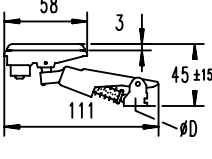
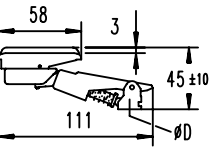
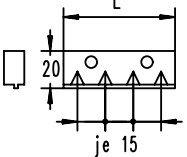
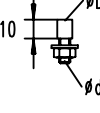
If you are in demand of any of the components listed below for existing systems, then, for your order, please pay attention, if the respective components will still be available. If this is not the case, please verify, if new components of the current lists may be used as well.


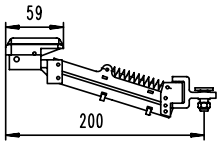


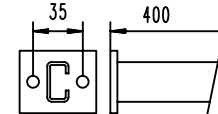
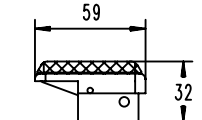
If the subsequent components are identified as available, please consider that they will be no longer produced in series. Therefore, your decision should be made, if possible, regarding our new components only.

Thus, the following list will provide information and orientation concerning the components which are outdated due to the fast technical development.

If you are in doubt, please contact us. We are sure to be able to suggest an acceptable solution.

Ser. No.		previous order no.	(see IS 100 B) replaced by order no.	* no longer available	available until
1		504 552.001 200 001 299 or 507 071.001 200 005 299 or 504 552.013 200 002 299	200 009 299 200 011 299 200 010 299	<b>Conductor rail;</b> metal rail 30 mm <sup>2</sup> ; FABA 40 standard-insul. orange, 3m  FABA 40 heat-resist. insl. black, 3 m  FABA 40 protect. conductor, green-yellow, 3 m	12/99 12/99 12/99
2		504 555.001 241 010 000	241 010 006	<b>Screw fixing point clip;</b> 2 pieces per fixed point are required	12/99
3		507 953.001 241 001 010	241 040 510 241 040 511 241 040 512	<b>Expansion housing ;</b> one part, plastic	12/99
4		506 934.001 241 016 006	241 025 020 241 025 021 241 025 022	<b>Separation cap</b> without power feed	12/99
5		507 151.001 241 023 150	241 025 023 241 025 024 241 025 025 241 025 026 241 025 027 241 025 028	<b>Separation cap</b> with power feed	12/99
6		504 550.001 241 016 025	as ser. no. 7 + 8	<b>Guiding cap</b>	12/99

Ser. no.		previous order no.	(see IS 100 B) replaced by order no	* no longer available	available until
7		or 504 549.001 241 017 000	241 017 045	<b>Transfer cap</b> , straight	12/99
8		or 507 164.001 241 018 060	241 017 055	<b>Transfer cap</b> , to be clamped, with power feed, straight	12/99
9		or 507 164.002 241 018 066	241 017 055	<b>Transfer cap</b> , to be clamped, with power feed, with upper diagonal cut, 45°	12/99
10		or 507 164.003 241 018 071	241 017 055	<b>Transfer cap</b> , to be clamped, with power feed, with lower diagonal cut, 45°	12/99
11		or 504 559.001 241 035 000 or 504 559.002 241 035 005	241 035 030 241 035 056	<b>Current collector</b> with small head ; <b>S 20</b> for conductor rail, Ø D = 8, orange ; <b>SL 20</b> for (PE) conductor rail, Ø D = 6, base - yellow	12/99 12/99
12		or 504 561.001 241 035 010 or 504 561.002 241 035 015	241 035 030 241 035 056	<b>Current collector</b> for pick up guide; <b>S 20 T</b> for conductor rail, Ø D = 8, orange ; <b>SL 20 T</b> for PE conductor rail, Ø D = 6, base - yellow	12/99 12/99
13		504 570.001 504 570.002 504 570.003 504 570.004 504 570.005 504 570.006	IS 100 B page 26	<b>Centring</b> 1-pole L = 27 mm 2-poles L = 42 mm 3-poles L = 45 mm 4-poles L = 60 mm 5-poles L = 75 mm 6-poles L = 90 mm	12/99 12/99 12/99 12/99 12/99 12/99
14		or 504 562.001 241 013 020 or 504 562.002 241 013 021	IS 100 B page 26	<b>Fastening bolt</b> Ø D = 8, d = M6, for rail S 20 and S 20 T Ø D = 6, d = M4, for conductor rail SL 20 and SL 20 T	12/99 12/99

Ser. No.		previous order no.	(see IS 100 B) replaced by order no	* no longer available	available until
15		or 504 563.005 241 040 304 or 504 563.007 241 040 306	IS 100 B page 24	<b>Connecting cable</b> 1 m long ; with straight plug ;  for S 20 and S 20 T  for SL 20 and SL 20 T	12/99  12/99
16		or 506 996.001 241 035 065 or 506 996.002 241 035 070	241 035 160  241 035 161	<b>Parallel arm-current collector</b> , without connecting cable width of head and base: 17 mm <b>25 / 50 A</b>  <b>PE</b>	12/99  12/99
17		or 507 018.008 241 040 387 or 507 018.009 241 040 388	-----  -----	<b>Connecting cable</b> , 1.5 m long for above-mentioned parallel-arm current collector <b>25 A</b>  <b>PE</b>	12/99  12/99
18		or 507 018.006 241 040 385 or 507 018.007 241 040 386	-----  -----	<b>Connecting cable</b> , 1.5 m long for above-mentioned parallel-arm current collector <b>50 A</b>  <b>PE</b>	12/99  12/99
19		or 504 703.001 244 013 010	-----	<b>Supporting arm</b> , 400 long C-rail 28 x 15 for above-mentioned parallel-arm current collector	12/99
20		or 507 021.001 241 035 270 or 507 021.002 241 035 275	-----  -----	<b>Replacement head</b> for connection M5 für above-mentioned parallel-arm current collector <b>Cu collector shoe</b>  <b>PE</b>	12/99  12/99